

SOT-23 Plastic-Encapsulate Diodes

MMBZ5221C-MMBZ5259C ZENER DIODE

FEATURES

- Planar Die Construction
- General Purpose, Medium Current
- Ideally Suited for Automated Assembly

Marking:

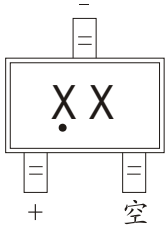

XX= Device code, see table on page2 the marking code

Solid dot = Green molding compound device.

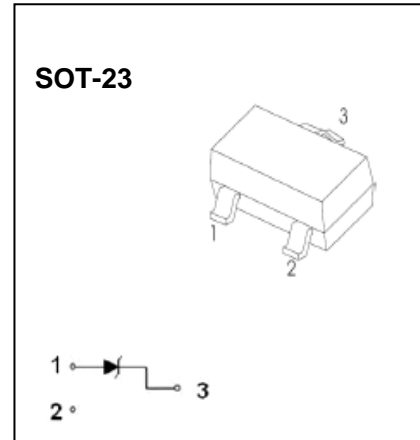

Maximum Ratings ($T_a=25^{\circ}\text{C}$ unless otherwise noted)

Characteristic	Symbol	Value	Unit
Forward Voltage @ $I_F=10\text{mA}$	V_F	0.9	V
Power Dissipation(Note 1)	P_D	300	mW
Thermal Resistance from Junction to Ambient (Note 1)	$R_{\theta JA}$	417	$^{\circ}\text{C/W}$
Operation Junction and Storage Temperature Range	T_J, T_{stg}	-55~+150	$^{\circ}\text{C}$

ELECTRICAL CHARACTERISTICS

T_a=25°C unless otherwise specified

Type Number	Marking Code	Zener Voltage Range (Note 1)			Test Current	Maximum Zener Impedance (Note 2)		Maximum Reverse Leakage Current (Note 1)	
		V _Z @ I _{ZT}				I _{ZT}	Z _{ZT} @ I _{ZT}	Z _{ZK} @ I _{ZK} =0.25mA	I _R
		Nom (V)	Min (V)	Max (V)	mA	Ω		μA	V
MMBZ5221C	2KC1	2.4	2.35	2.45	20	30	1200	100	1.0
MMBZ5222C	2KC2	2.5	2.45	2.55	20	30	1250	100	1.0
MMBZ5223C	2KC3	2.7	2.65	2.75	20	30	1300	75	1.0
MMBZ5225C	2KC5	3.0	2.94	3.06	20	30	1600	50	1.0
MMBZ5226C	2KG1	3.3	3.23	3.37	20	28	1600	25	1.0
MMBZ5227C	2KG2	3.6	3.53	3.67	20	24	1700	15	1.0
MMBZ5228C	2KG3	3.9	3.82	3.98	20	23	1900	10	1.0
MMBZ5229C	2KG4	4.3	4.21	4.39	20	22	2000	5.0	1.0
MMBZ5230C	2KG5	4.7	4.61	4.79	20	19	1900	5.0	2.0
MMBZ5231C	2KE1	5.1	5.00	5.20	20	17	1600	5.0	2.0
MMBZ5232C	2KE2	5.6	5.49	5.71	20	11	1600	5.0	3.0
MMBZ5233C	2KE3	6.0	5.88	6.12	20	7	1600	5.0	3.5
MMBZ5234C	2KE4	6.2	6.08	6.32	20	7	1000	5.0	4.0
MMBZ5235C	2KE5	6.8	6.66	6.94	20	5	750	3.0	5.0
MMBZ5236C	2KF1	7.5	7.35	7.65	20	6	500	3.0	6.0
MMBZ5237C	2KF2	8.2	8.04	8.36	20	8	500	3.0	6.5
MMBZ5238C	2KF3	8.7	8.53	8.87	20	8	600	3.0	6.5
MMBZ5239C	2KF4	9.1	8.92	9.28	20	10	600	3.0	7.0
MMBZ5240C	2KF5	10	9.80	10.20	20	17	600	3.0	8.0
MMBZ5241C	2KH1	11	10.78	11.22	20	22	600	2.0	8.4
MMBZ5242C	2KH2	12	11.76	12.24	20	30	600	1.0	9.1
MMBZ5243C	2KH3	13	12.74	13.26	9.5	13	600	0.5	9.9
MMBZ5244C	2KH4	14	13.72	14.28	9.0	15	600	0.1	10
MMBZ5245C	2KH5	15	14.70	15.30	8.5	16	600	0.1	11
MMBZ5246C	2KJ1	16	15.68	16.32	7.8	17	600	0.1	12
MMBZ5247C	2KJ2	17	16.66	17.34	7.4	19	600	0.1	13
MMBZ5248C	2KJ3	18	17.64	18.36	7.0	21	600	0.1	14
MMBZ5249C	2KJ4	19	18.62	19.38	6.6	23	600	0.1	14
MMBZ5250C	2KJ5	20	19.60	20.40	6.2	25	600	0.1	15
MMBZ5251C	2KK1	22	21.56	22.44	5.6	29	600	0.1	17
MMBZ5252C	2KK2	24	23.52	24.48	5.2	33	600	0.1	18
MMBZ5253C	2KK3	25	24.50	25.50	5.0	35	600	0.1	19
MMBZ5254C	2KK4	27	26.46	27.54	5.0	41	600	0.1	21
MMBZ5255C	2KK5	28	27.44	28.56	4.5	44	600	0.1	21
MMBZ5256C	2KM1	30	29.40	30.60	4.2	49	600	0.1	23
MMBZ5257C	2KM2	33	32.34	33.66	3.8	58	700	0.1	25
MMBZ5258C	2KM3	36	35.28	36.72	3.4	70	700	0.1	27
MMBZ5259C	2KM4	39	38.22	39.78	3.2	80	800	0.1	30

Note: 1. Short duration pulse test used to minimize self-heating effect.

2. f = 1kHz.

Typical Characteristics

Notes: Our company currently provide 5.1 V - 20 V products only

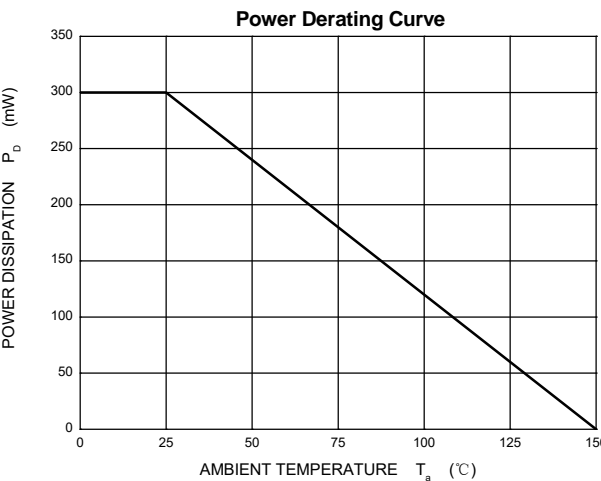
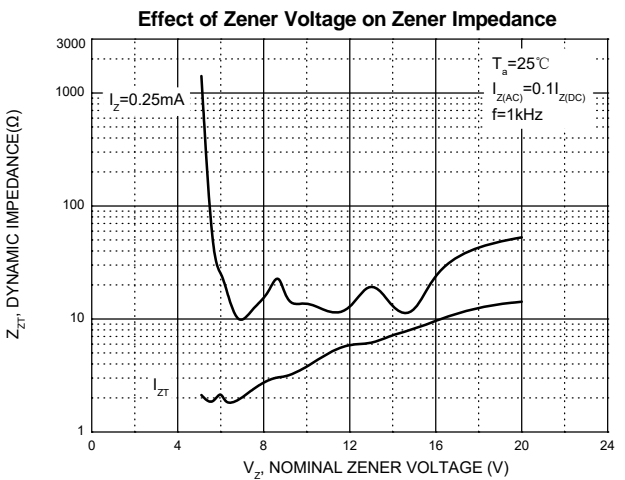
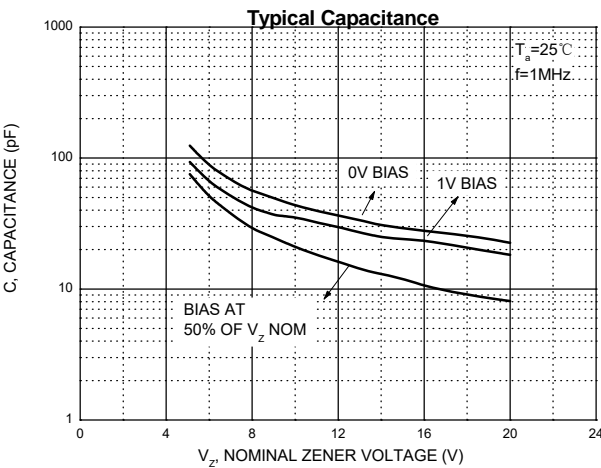
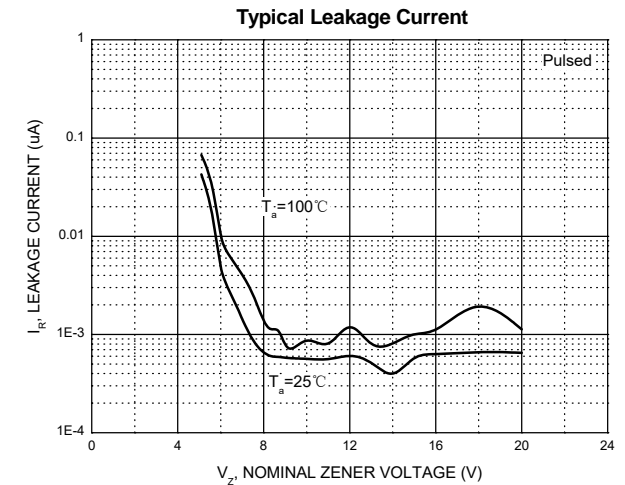
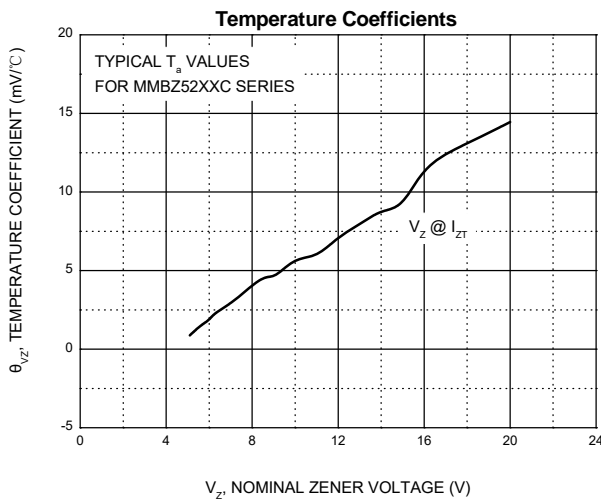
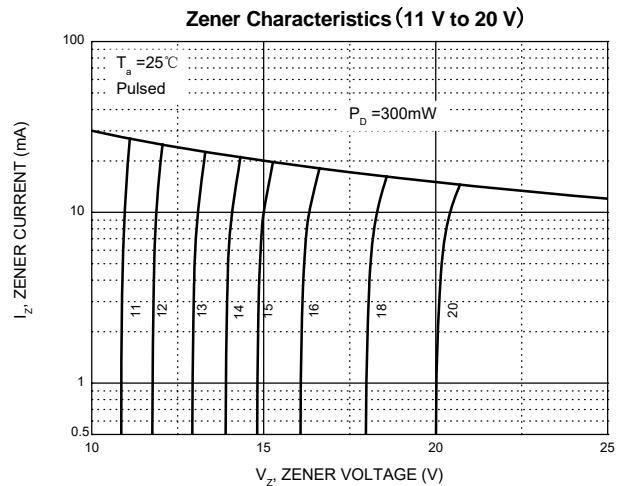
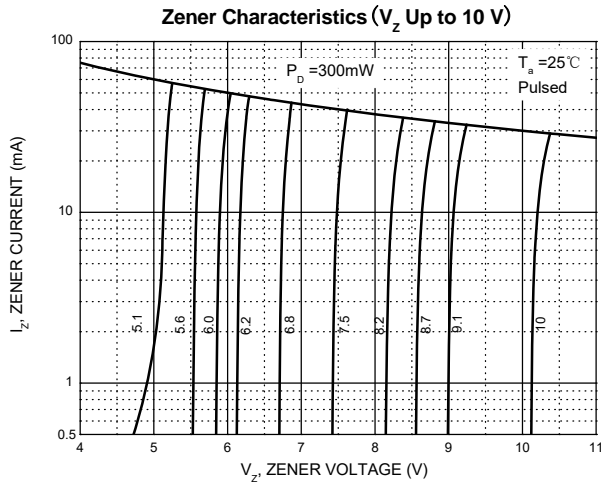

SOT-23 Package Outline Dimensions

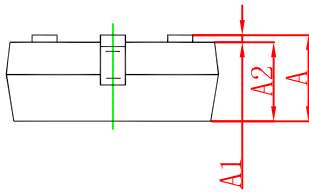
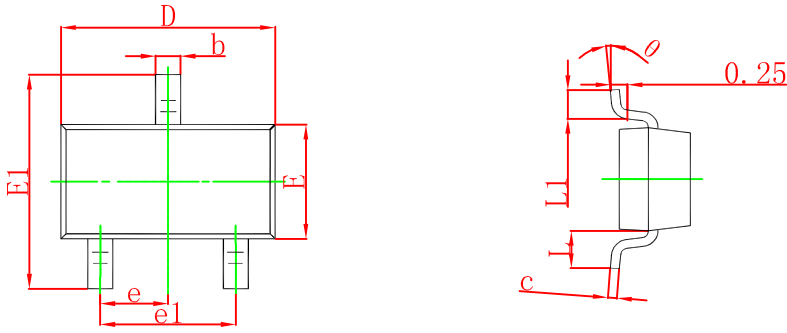

Symbol	Dimensions In Millimeters		Dimensions In Inches	
	Min	Max	Min	Max
A	0.900	1.150	0.035	0.045
A1	0.000	0.100	0.000	0.004
A2	0.900	1.050	0.035	0.041
b	0.300	0.500	0.012	0.020
c	0.080	0.150	0.003	0.006
D	2.800	3.000	0.110	0.118
E	1.200	1.400	0.047	0.055
E1	2.250	2.550	0.089	0.100
e	0.950 TYP		0.037 TYP	
e1	1.800	2.000	0.071	0.079
L	0.550 REF		0.022 REF	
L1	0.300	0.500	0.012	0.020
θ	0°	8°	0°	8°

SOT-23 Suggested Pad Layout

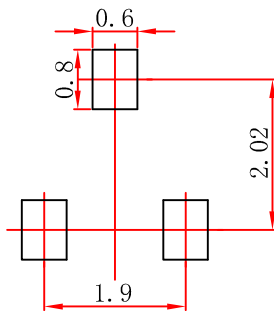

Note:

1. Controlling dimension: in millimeters.
2. General tolerance: $\pm 0.05\text{mm}$.
3. The pad layout is for reference purposes only.

NOTICE

JSCJ reserves the right to make modifications, enhancements, improvements, corrections or other changes without further notice to any product herein. JSCJ does not assume any liability arising out of the application or use of any product described herein.

SOT-23 Tape and Reel

SOT-23 Embossed Carrier Tape

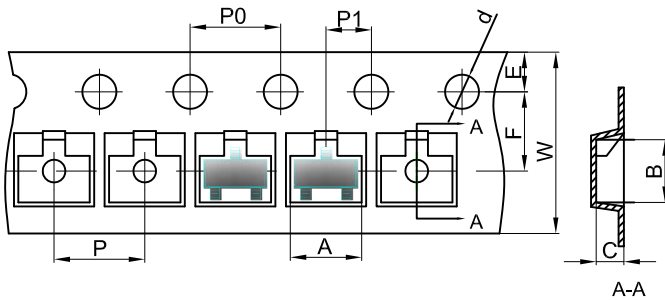

Packaging Description:

SOT-23 parts are shipped in tape. The carrier tape is made from a dissipative (carbon filled) polycarbonate resin. The cover tape is a multilayer film (Heat Activated Adhesive in nature) primarily composed of polyester film, adhesive layer, sealant, and anti-static sprayed agent. These reeled parts in standard option are shipped with 3,000 units per 7" or 17.8cm diameter reel. The reels are clear in color and is made of polystyrene plastic (anti-static coated).

Dimensions are in millimeter

Pkg type	A	B	C	d	E	F	P0	P	P1	W
SOT-23	3.15	2.77	1.22	Ø1.50	1.75	3.50	4.00	4.00	2.00	8.00

SOT-23 Tape Leader and Trailer

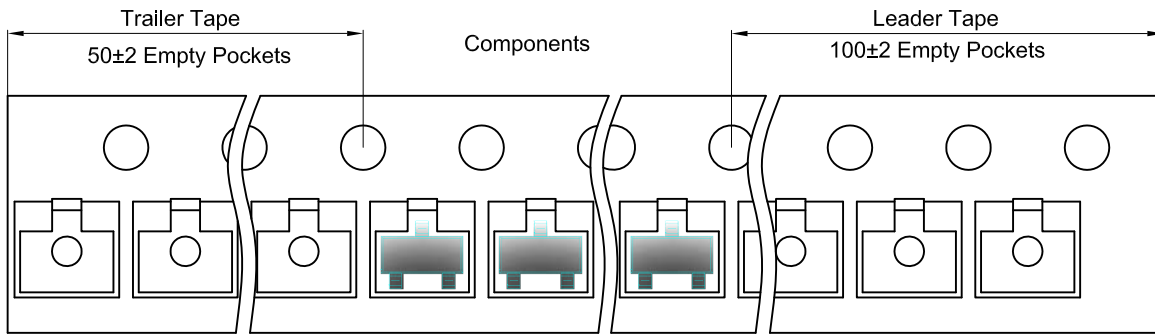

SOT-23 Reel

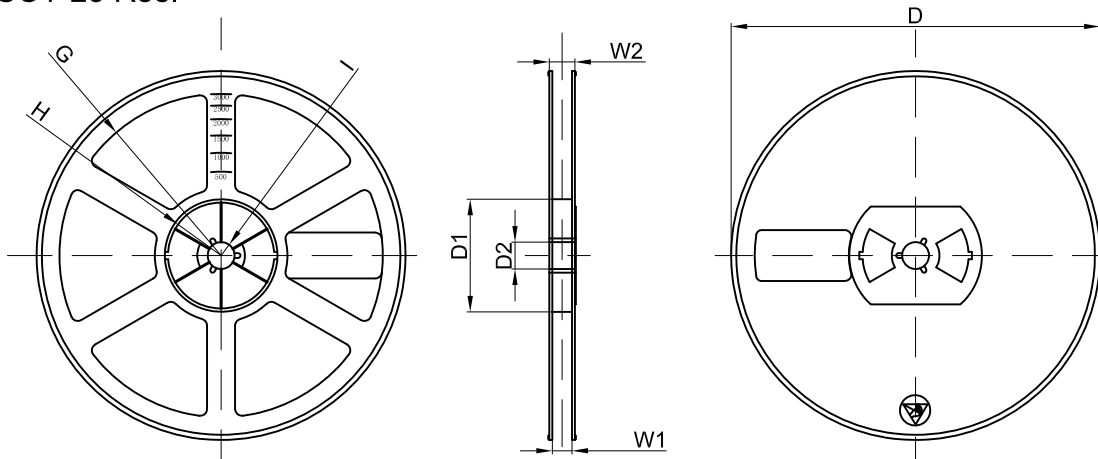

Dimensions are in millimeter

Reel Option	D	D1	D2	G	H	I	W1	W2
7"Dia	Ø178.00	54.40	13.00	R78.00	R25.60	R6.50	9.50	12.30

REEL	Reel Size	Box	Box Size(mm)	Carton	Carton Size(mm)	G.W.(kg)
3000 pcs	7 inch	45,000 pcs	203×203×195	180,000 pcs	438×438×220	