

## TO-220-2L Plastic-Encapsulate Diode

**MUR15H120** HYPERFAST RECTIFIER,FRED

### MAIN CHARACTERISTICS

<b>I<sub>o</sub></b>	<b>15A</b>
<b>V<sub>RRM</sub></b>	<b>1200V</b>
<b>T<sub>rr</sub></b>	<b>24ns</b>
<b>T<sub>j</sub></b>	<b>175°C</b>
<b>V<sub>F(typ)</sub></b>	<b>1.8V(@T<sub>j</sub>=150°C)</b>

### FEATURES

- Ultrafast Recovery Times and Low Recovery Loss
- Low Forward Voltage
- Low Reverse Leakage Current

### APPLICATIONS

Specifically designed to improve efficiency of PFC and output rectification stages of EV / HEV battery charging stations, booster stage of solar inverters and UPS applications, these devices are perfectly matched to operate with MOSFETs or high speed IGBTs.

### MARKING

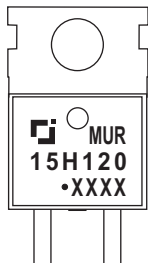

MUR15H120 = Device code  
 Solid dot = Green molding compound device  
 if none, the normal device  
 XXXX = Code

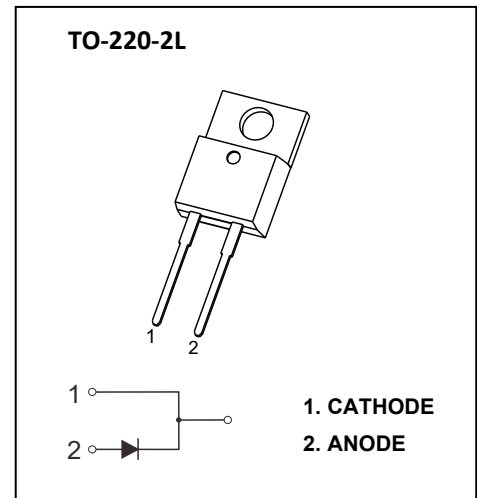

### MAXIMUM RATINGS ( T<sub>c</sub>=25°C unless otherwise noted )

Symbol	Parameter	MUR15H120	Unit
<b>V<sub>RRM</sub></b>	Peak Repetitive Reverse Voltage	1200	V
<b>V<sub>R</sub></b>	DC Blocking Voltage		
<b>I<sub>F(AV)</sub></b>	Average Forward Current(T <sub>c</sub> =115°C)	15	A
<b>I<sub>F(RMS)</sub></b>	RMS Forward Current(T <sub>c</sub> =115°C)	21	A
<b>I<sub>FSM</sub></b>	Non-Repetitive Surge Forward Current (8.3ms )	144	A
<b>P<sub>D</sub></b>	Power dissipation	79	W
<b>R<sub>θJC</sub></b>	Thermal Resistance From Junction to Case	1.9	°C/W
<b>T<sub>j</sub></b>	Operating Junction Temperature Range	-55 ~ +175	°C
<b>T<sub>stg</sub></b>	Storage Temperature Range	-55 ~ +175	°C

# Typical Characteristics

## ELECTRICAL CHARACTERISTICS ( $T_C=25^\circ\text{C}$ unless otherwise specified)

Symbol	Parameter	Test Conditions	Min.	Typ.	Max.	Unit
$V_{(BR)}$	Reverse Voltage	$I_R=100\mu\text{A}$	1200			V
$I_R$	Reverse Current	$V_R=1200\text{V}$	$T_J=25^\circ\text{C}$		10	$\mu\text{A}$
			$T_J=150^\circ\text{C}$		500	$\mu\text{A}$
$V_F$	Forward Voltage	$I_F=15\text{A}$	$T_J=25^\circ\text{C}$	2.6	3.2	V
			$T_J=150^\circ\text{C}$	1.8		V
$C_{tot}$	Total Capacitance	$V_R=200\text{V}, f=1\text{MHz}$		10		pF
$t_{rr}$	Reverse Recovery time	$I_F=0.5\text{A}, I_R=1\text{A}, I_{rr}=0.25\text{A}$		31		ns
		$I_F=1\text{A}, V_R=30\text{V}, di_F/dt = 200\text{A}/\mu\text{s}$		24		ns

## ELECTRICAL CHARACTERISTICS ( $T_C=25^\circ\text{C}$ unless otherwise specified)

Symbol	Parameter	Test Conditions	Min.	Typ.	Max.	Unit
$t_{rr}$	Reverse Recovery Time	$I_F=15\text{A}, V_R=600\text{V}, di_F/dt=200\text{A}/\mu\text{s}$		50		ns
$I_{RRM}$	Max. Reverse Recovery Current			5.0		A
$Q_{rr}$	Reverse Recovery Charge			149		nC
$t_{rr}$	Reverse Recovery Time	$I_F=15\text{A}, V_R=600\text{V}, di_F/dt=200\text{A}/\mu\text{s}, T_J=125^\circ\text{C}$		226		ns
$I_{RRM}$	Max. Reverse Recovery Current			10		A
$Q_{rr}$	Reverse Recovery Charge			1384		nC
$t_{rr}$	Reverse Recovery Time	$I_F=15\text{A}, V_R=600\text{V}, di_F/dt=600\text{A}/\mu\text{s}, T_J=125^\circ\text{C}$		115		ns
$I_{RRM}$	Max. Reverse Recovery Current			22		A
$Q_{rr}$	Reverse Recovery Charge			1515		nC

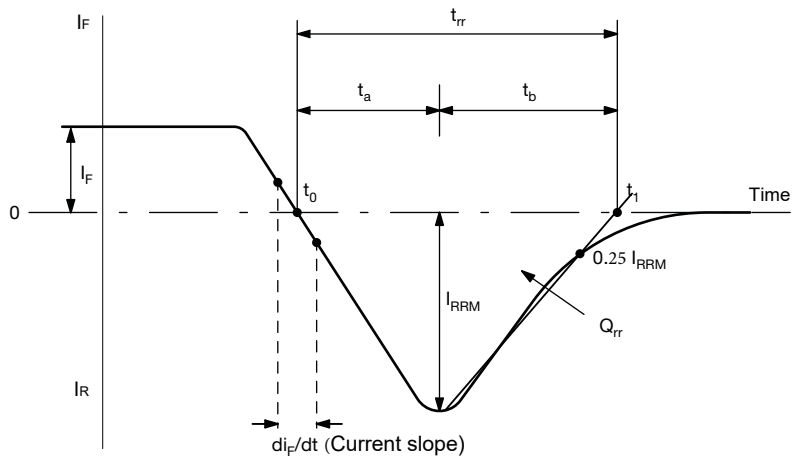

Reverse Recovery Waveform and Definitions

# Typical Characteristics

### Forward Characteristics

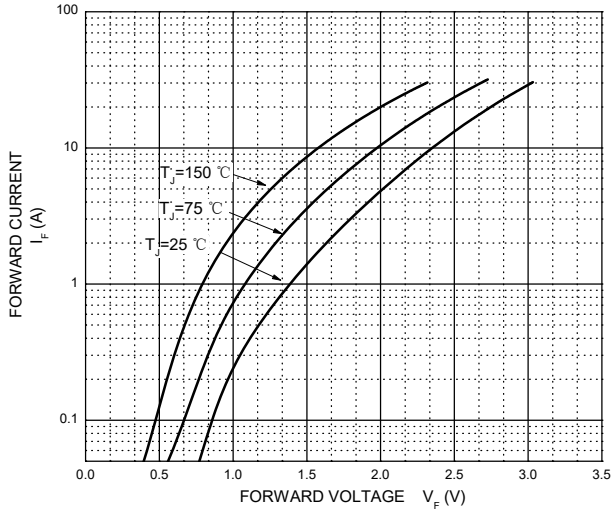

### Reverse Characteristics

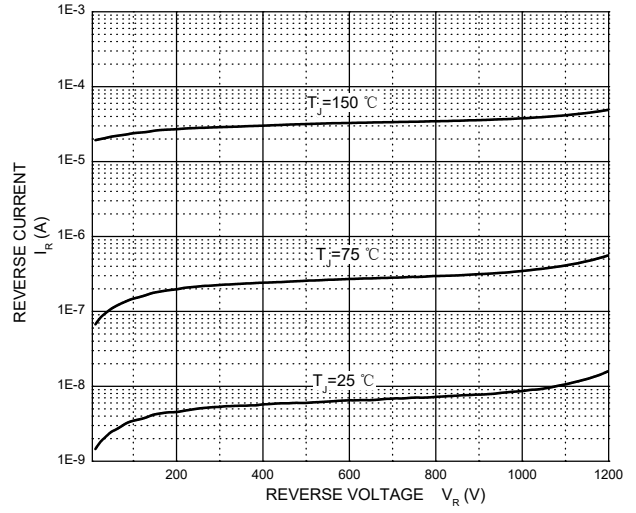

### Capacitance Characteristics Per Diode

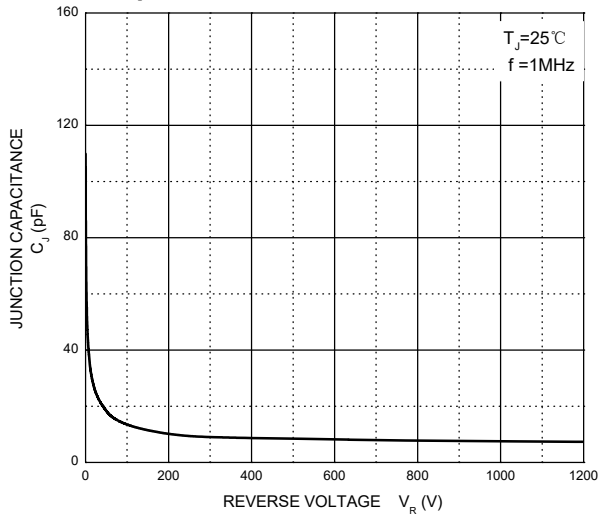

### Recovery Current vs. $di_F/dt$

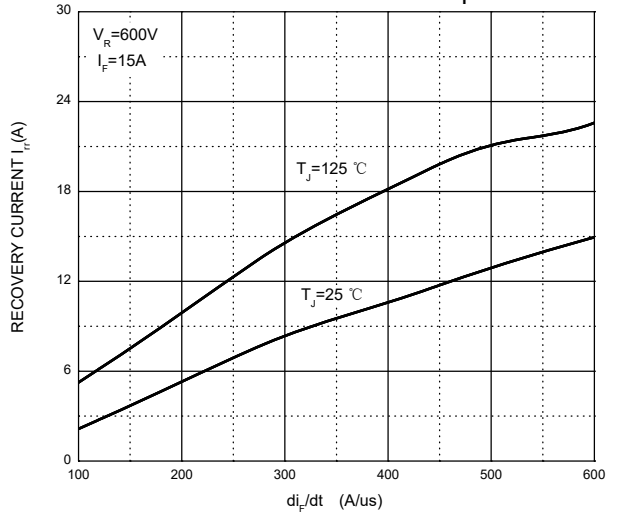

### Reverse Recovery Time vs. $di_F/dt$

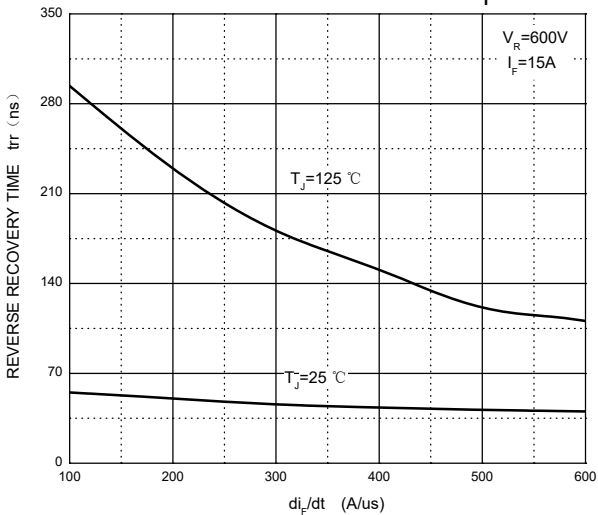

### Stored Charge vs. $di_F/dt$

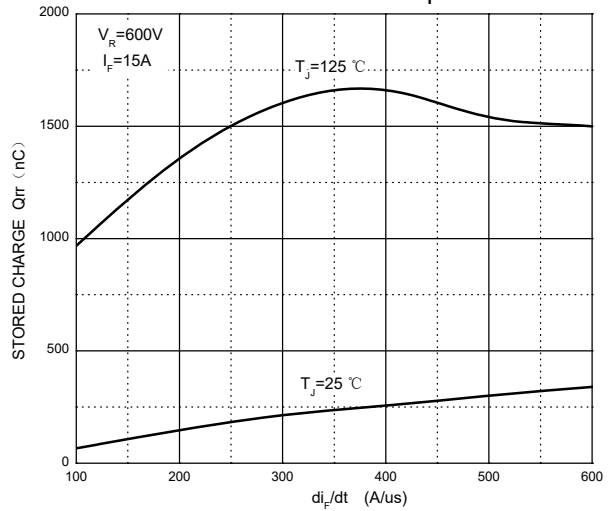

# Typical Characteristics

### Dynamic Parameters vs. Junction Temperature

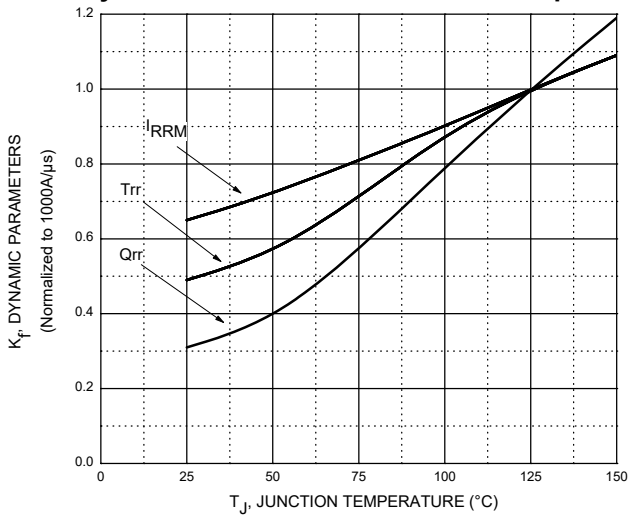

### Current Derating

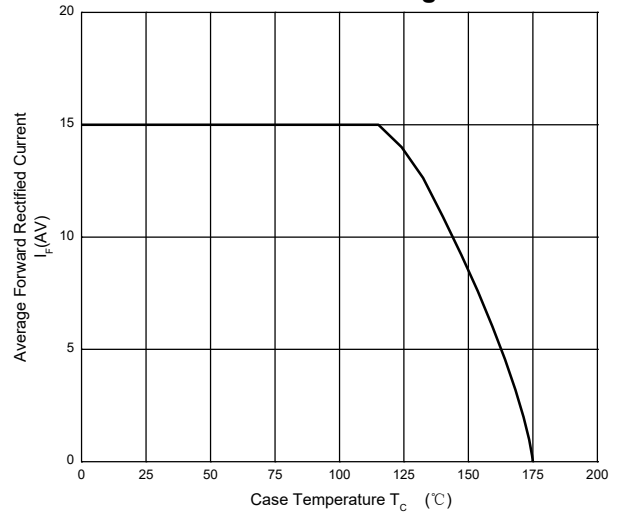

### MUR15H120 Transient Thermal Impedance, Junction-Case

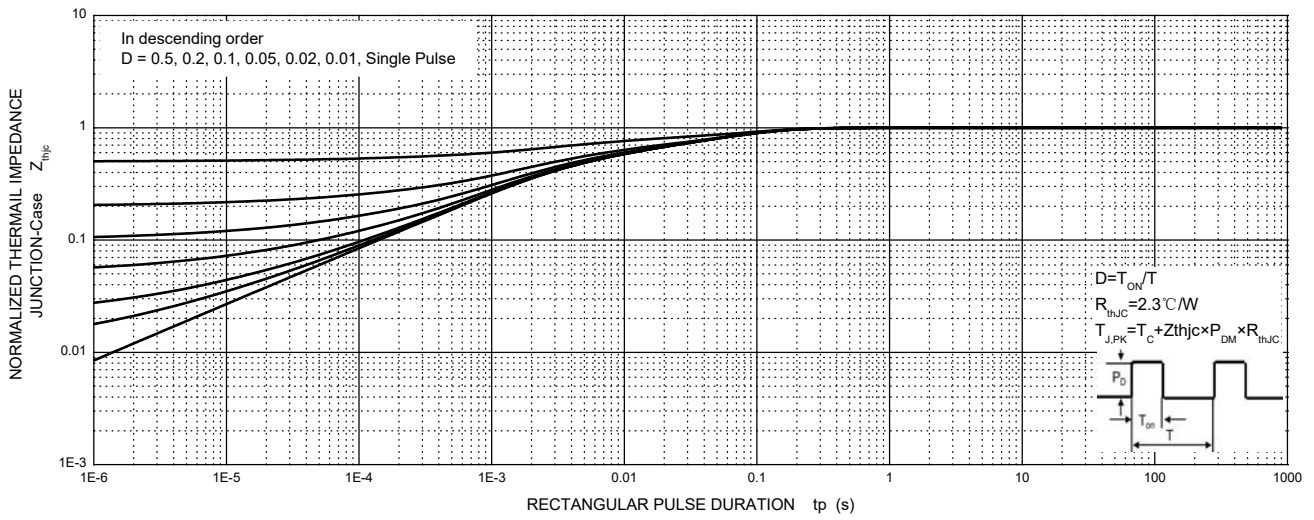

# TO-220-2L Package Outline Dimensions

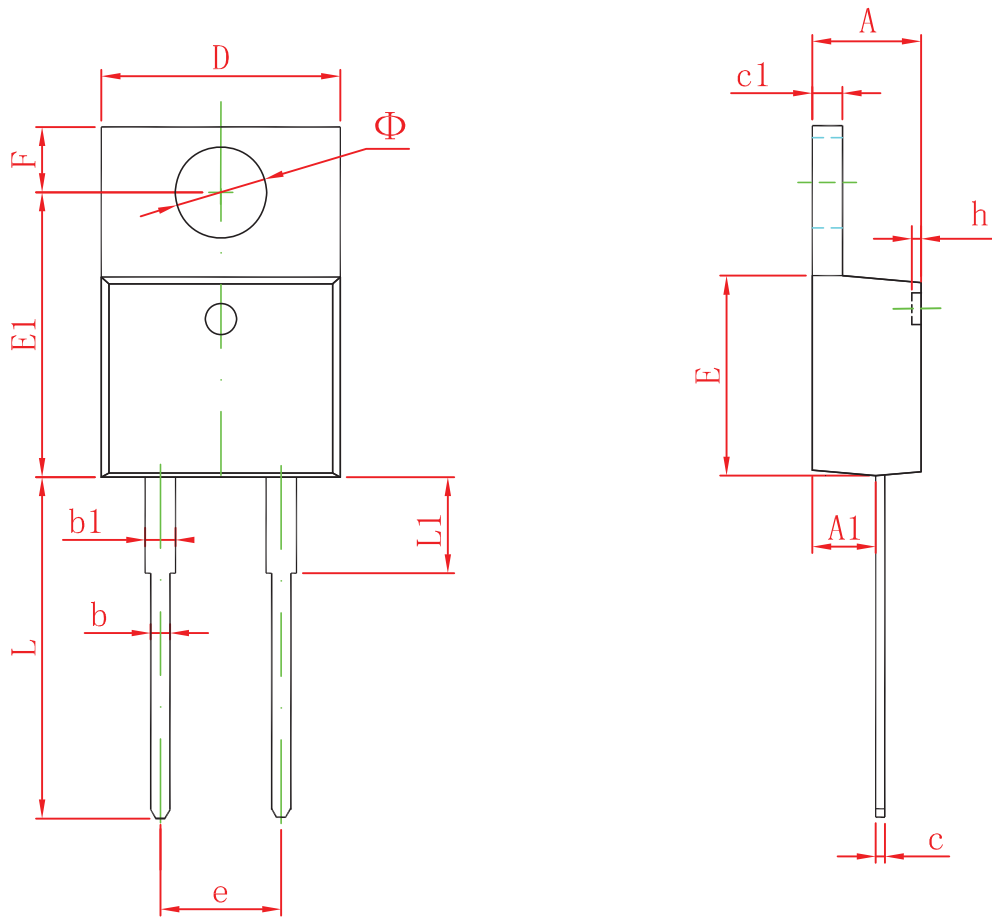

Symbol	Dimensions In Millimeters		Dimensions In Inches	
	Min	Max	Min	Max
A	4.450	4.750	0.175	0.187
A1	2.520	2.820	0.099	0.111
b	0.710	0.910	0.028	0.036
b1	1.170	1.370	0.046	0.054
c	0.300	0.500	0.012	0.020
c1	1.170	1.370	0.046	0.054
D	9.830	10.330	0.387	0.407
E	8.500	8.900	0.335	0.350
E1	12.050	12.650	0.474	0.498
e	5.080 TYP		0.200 TYP	
F	2.540	2.940	0.100	0.116
h	0.100 TYP		0.004 TYP	
L	13.300	13.800	0.523	0.543
L1	3.540	3.940	0.139	0.155
$\Phi$	3.735	3.935	0.147	0.155