



TO-247-2L Plastic-Encapsulate Diode

MURW60H120 HYPERFAST RECTIFIER, FRED

MAIN CHARACTERISTICS

I_o	60A
V_{RRM}	1200V
T_{rr}	33ns
T_j	175°C
$V_{F(typ)}$	2.0V(@$T_j=150^\circ\text{C}$)

FEATURES

- Ultrafast Recovery Times and Low Recovery Loss
- Low Forward Voltage
- Low Reverse Leakage Current

APPLICATIONS

Specifically designed to improve efficiency of PFC and output rectification stages of EV / HEV battery charging stations, booster stage of solar inverters and UPS applications, these devices are perfectly matched to operate with MOSFETs or high speed IGBTs.

MARKING

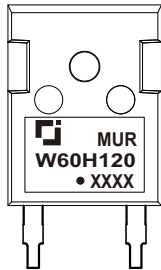

MURW60H120= Device code
 Solid dot = Green molding compound device
 if none, the normal device
 XXXX = Code

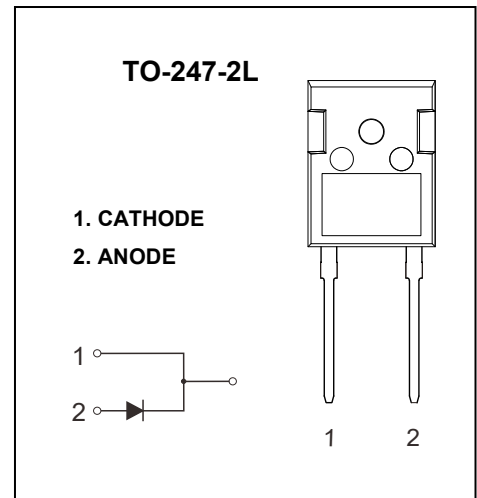

MAXIMUM RATINGS ($T_c=25^\circ\text{C}$ unless otherwise noted)

Symbol	Parameter	MURW60H120	Unit
V_{RRM}	Peak Repetitive Reverse Voltage	1200	V
V_R	DC Blocking Voltage		
$I_{F(AV)}$	Average Forward Current($T_c=121^\circ\text{C}$)	60	A
$I_{F(RMS)}$	RMS Forward Current($T_c=121^\circ\text{C}$)	84.8	A
I_{FSM}	Non-Repetitive Surge Forward Current (8.3ms)	500	A
P_D	Power dissipation	341	W
$R_{\theta JC}$	Thermal Resistance From Junction to Case	0.44	$^\circ\text{C}/\text{W}$
T_j	Operating Junction Temperature Range	-55 ~ +175	$^\circ\text{C}$
T_{stg}	Storage Temperature Range	-55 ~ +175	$^\circ\text{C}$

Typical Characteristics

ELECTRICAL CHARACTERISTICS ($T_c=25^\circ\text{C}$ unless otherwise specified)

Symbol	Parameter	Test Conditions	Min.	Typ.	Max.	Unit
$V_{(BR)}$	Reverse Voltage	$I_R=100\mu\text{A}$	1200			V
I_R	Reverse Current	$V_R=1200\text{V}$	$T_j=25^\circ\text{C}$		10	μA
			$T_j=150^\circ\text{C}$		800	μA
V_F	Forward Voltage	$I_F=60\text{A}$	$T_j=25^\circ\text{C}$	2.8	3.5	V
			$T_j=150^\circ\text{C}$	2.0		V
C_{tot}	Total Capacitance	$V_R=200\text{V}, f=1\text{MHz}$		47		pF
trr	Reverse Recovery time	$I_F=0.5\text{A}, I_R=1\text{A}, I_{rr}=0.25\text{A}$		43		ns
		$I_F=1\text{A}, V_R=30\text{V}, di_F/dt = 200\text{A/us}$		33		ns

ELECTRICAL CHARACTERISTICS ($T_c=25^\circ\text{C}$ unless otherwise specified)

Symbol	Parameter	Test Conditions	Min.	Typ.	Max.	Unit
trr	Reverse Recovery Time	$I_F=60\text{A}, V_R=600\text{V}, di_F/dt=200\text{A}/\mu\text{s}$		152		ns
I_{RRM}	Max. Reverse Recovery Current			6		A
Qrr	Reverse Recovery Charge			547		nC
trr	Reverse Recovery Time	$I_F=60\text{A}, V_R=600\text{V}, di_F/dt=200\text{A}/\mu\text{s}, T_j=125^\circ\text{C}$		248		ns
I_{RRM}	Max. Reverse Recovery Current			21		A
Qrr	Reverse Recovery Charge			2752		nC
trr	Reverse Recovery Time	$I_F=60\text{A}, V_R=600\text{V}, di_F/dt=600\text{A}/\mu\text{s}, T_j=125^\circ\text{C}$		195		ns
I_{RRM}	Max. Reverse Recovery Current			32		A
Qrr	Reverse Recovery Charge			3453		nC

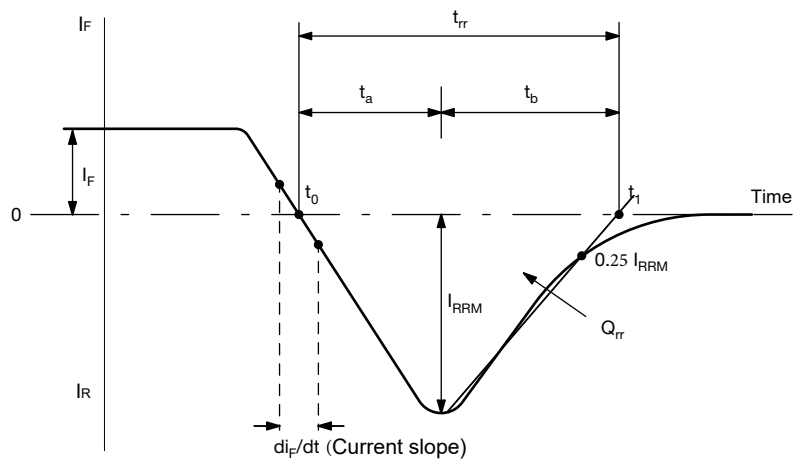

Reverse Recovery Waveform and Definitions

Typical Characteristics

Forward Characteristics

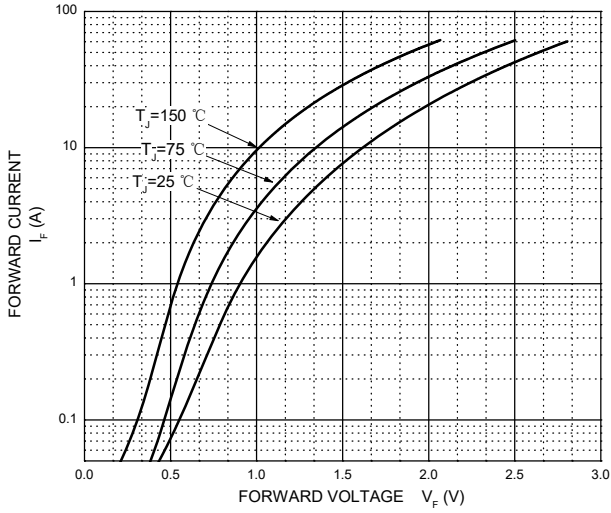

Reverse Characteristics

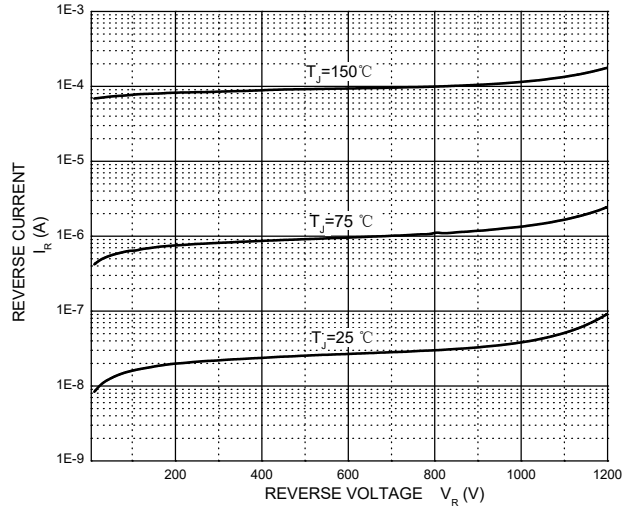

Capacitance Characteristics

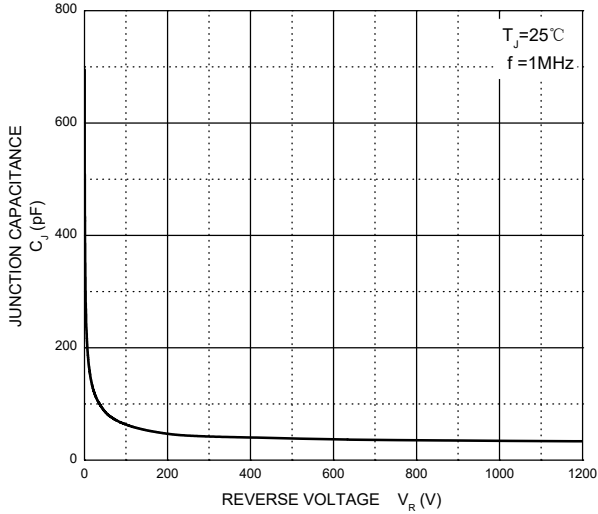

Recovery Current vs. di_F/dt

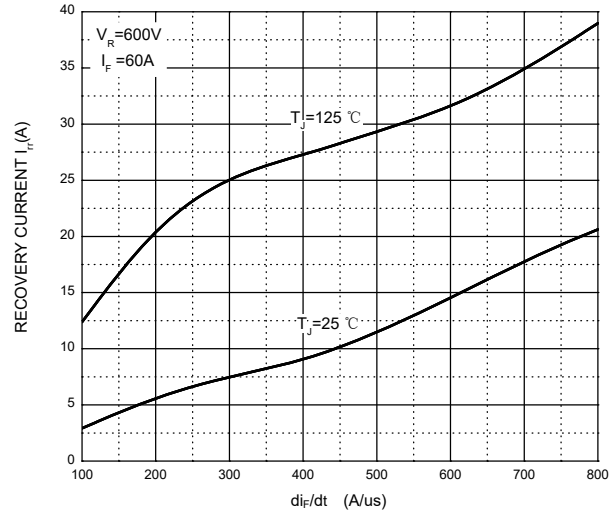

Reverse Recovery Time vs. di_F/dt

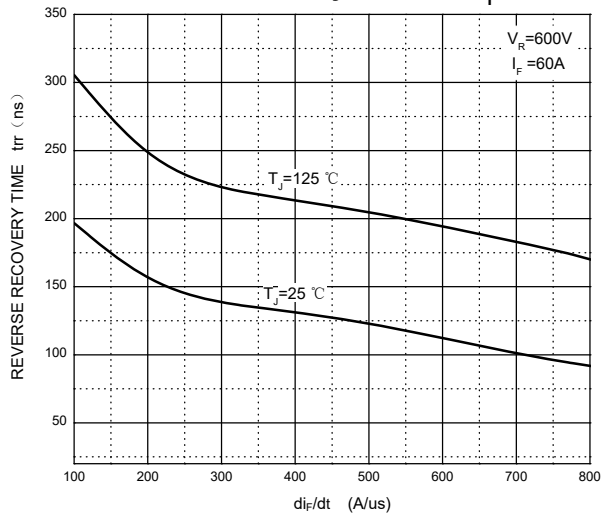

Stored Charge vs. di_F/dt

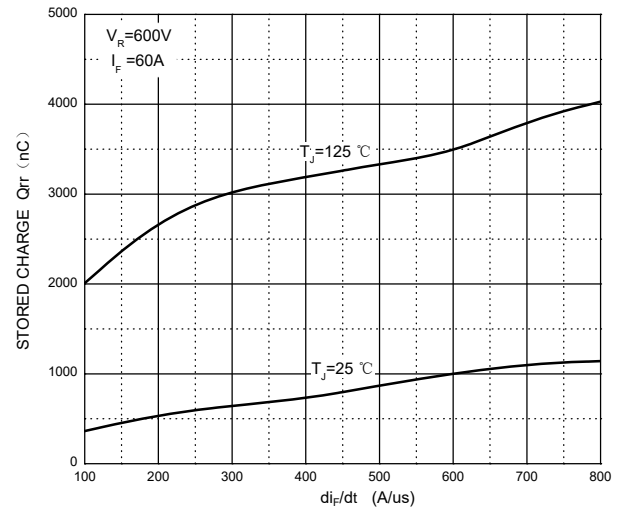

Typical Characteristics

Dynamic Parameters vs. Junction Temperature

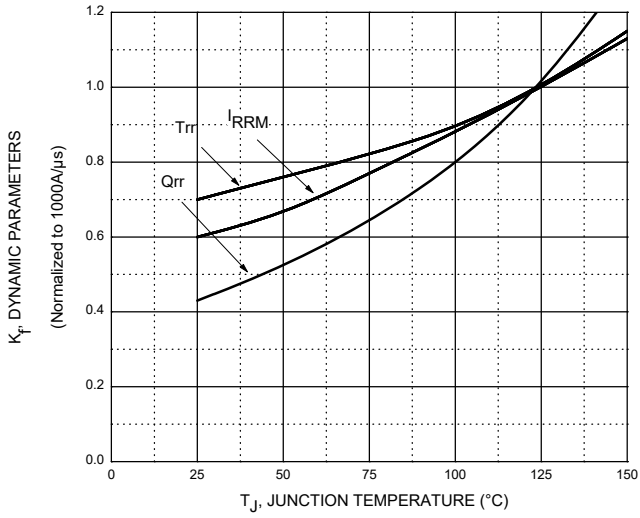

Current Derating

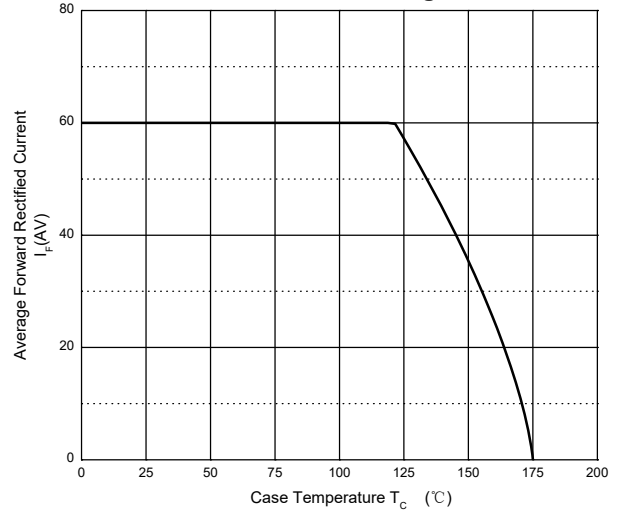

MURW60H120 Transient Thermal Impedance, Junction-Case

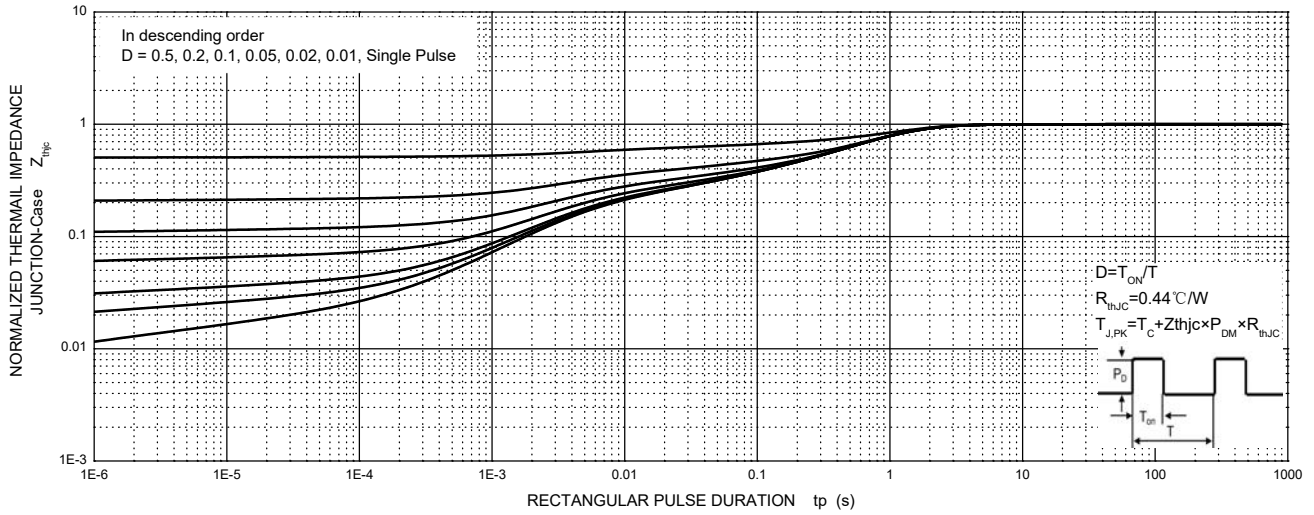

TO-247-2L Package Outline Dimensions

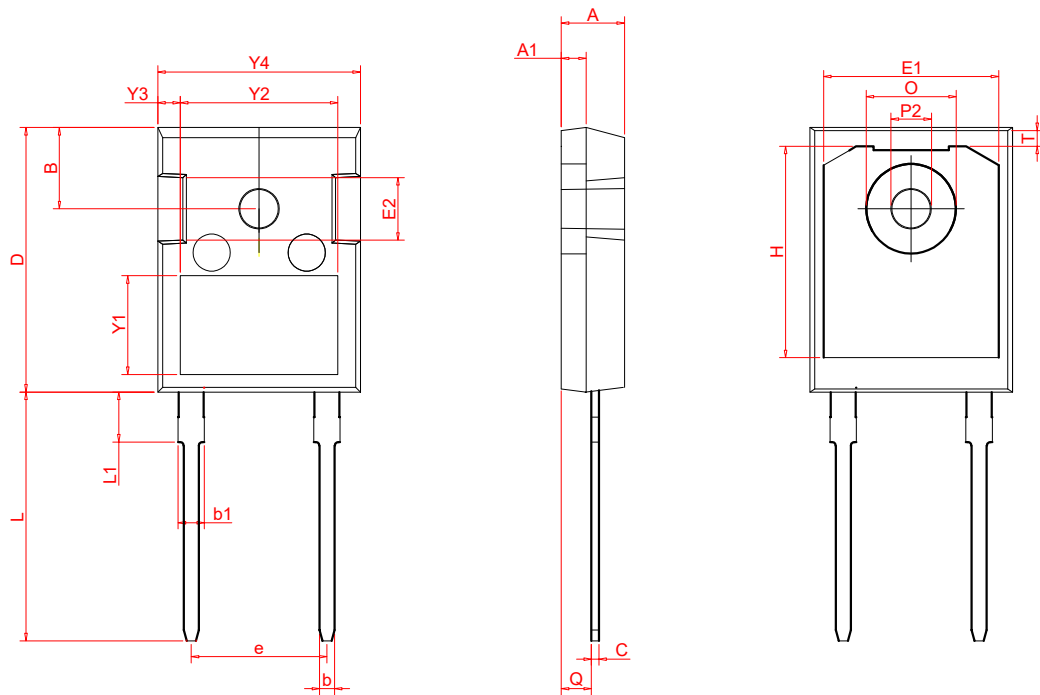

Symbol	Dimensions In Millimeters		Dimensions In Inches	
	Min	Max	Min	Max
A	4.70	5.30	0.185	0.209
A1	1.70	2.30	0.067	0.091
C	0.45	0.75	0.018	0.030
Q	2.20	2.60	0.087	0.102
O	7.10	7.40	0.280	0.291
P2	3.45	3.75	0.136	0.148
L	19.00	21.00	0.748	0.827
L1	4.20	4.50	0.165	0.177
b	1.00	1.40	0.039	0.055
b1	1.80	2.25	0.071	0.089
e	10.65	10.95	0.419	0.431
D	20.95	21.35	0.825	0.841
Y1	7.60	8.10	0.299	0.319
Y2	11.00	13.00	0.433	0.512
Y3	1.75	2.25	0.069	0.089
Y4	16.00	16.40	0.630	0.646
E2	4.60	4.90	0.181	0.193
T	1.35REF		0.053REF	
H	16.25REF		0.640REF	
E1	14.00REF		0.551REF	
B	6.55REF		0.258REF	