



TO-247 Plastic-Encapsulate Diode

MURW60H40LCTB HYPERFAST RECTIFIER, FRED

MAIN CHARACTERISTICS

I_o	60(30×2)A
V_{RRM}	400V
T_{rr}	25ns
T_j	175℃
$V_{F(typ)}$	0.94V(@$T_j=150℃$)

FEATURES

- Ultrafast Recovery Times and Low Recovery Loss
- Low Forward Voltage
- Low Reverse Leakage Current

APPLICATIONS

Specifically designed to improve efficiency of PFC and output rectification stages of EV / HEV battery charging stations, booster stage of solar inverters and UPS applications, these devices are perfectly matched to operate with MOSFETs or high speed IGBTs.

MARKING

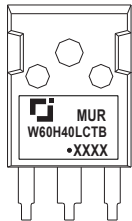

MURW60H40LCTB = Device code
 Solid dot = Green molding compound device
 if none, the normal device
 XXXX = Code

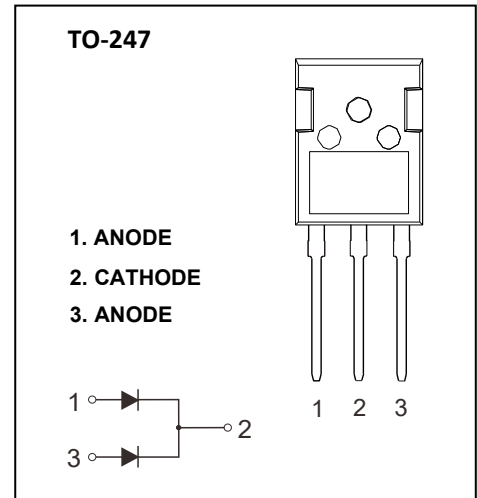

MAXIMUM RATINGS ($T_c=25℃$ unless otherwise noted)

Symbol	Parameter	MURW60H40LCTB	Unit
V_{RRM}	Peak Repetitive Reverse Voltage	400	V
V_R	DC Blocking Voltage		
$I_{F(AV)}$	Average rectified output current@ Per leg($T_c=148℃$)	30	A
	Average rectified output current@ Total device($T_c=148℃$)	60	
$I_{F(RMS)}$	RMS Forward Current($T_c=148℃$)	42	A
I_{FSM}	Non-Repetitive Surge Forward Current (8.3ms)	376	A
P_D	Power dissipation	150	W
$R_{\theta JC}$	Thermal Resistance From Junction to Case@ Per leg	1.0	℃/W
T_j	Operating Junction Temperature Range	-55 ~ +175	℃
T_{stg}	Storage Temperature Range	-55 ~ +175	℃

Typical Characteristics

ELECTRICAL CHARACTERISTICS ($T_C=25^\circ\text{C}$ unless otherwise specified)

Symbol	Parameter	Test Conditions	Min.	Typ.	Max.	Unit
$V_{(BR)}$	Reverse Voltage	$I_R=100\mu\text{A}$	400			V
I_R	Reverse Current	$V_R=400\text{V}$	$T_J=25^\circ\text{C}$		10	μA
			$T_J=150^\circ\text{C}$		800	μA
V_F	Forward Voltage	$I_F=30\text{A}$	$T_J=25^\circ\text{C}$	1.15	1.4	V
			$T_J=150^\circ\text{C}$	0.94		V
C_{tot}	Total Capacitance	$V_R=200\text{V}, f=1\text{MHz}$		56		pF
t_{rr}	Reverse Recovery time	$I_F=0.5\text{A}, I_R=1\text{A}, I_{rr}=0.25\text{A}$		32		ns
		$I_F=1\text{A}, V_R=30\text{V}, di_F/dt=200\text{A}/\mu\text{s}$		25		ns

ELECTRICAL CHARACTERISTICS ($T_C=25^\circ\text{C}$ unless otherwise specified)

Symbol	Parameter	Test Conditions	Min.	Typ.	Max.	Unit
t_{rr}	Reverse Recovery Time	$I_F=30\text{A}, V_R=200\text{V}, di_F/dt=200\text{A}/\mu\text{s}$		52		ns
I_{RRM}	Max. Reverse Recovery Current			4		A
Q_{rr}	Reverse Recovery Charge			121		nC
t_{rr}	Reverse Recovery Time	$I_F=30\text{A}, V_R=200\text{V}, di_F/dt=200\text{A}/\mu\text{s}, T_J=125^\circ\text{C}$		95		ns
I_{RRM}	Max. Reverse Recovery Current			10.5		A
Q_{rr}	Reverse Recovery Charge			526		nC
t_{rr}	Reverse Recovery Time	$I_F=30\text{A}, V_R=200\text{V}, di_F/dt=600\text{A}/\mu\text{s}, T_J=125^\circ\text{C}$		62		ns
I_{RRM}	Max. Reverse Recovery Current			27		A
Q_{rr}	Reverse Recovery Charge			906		nC

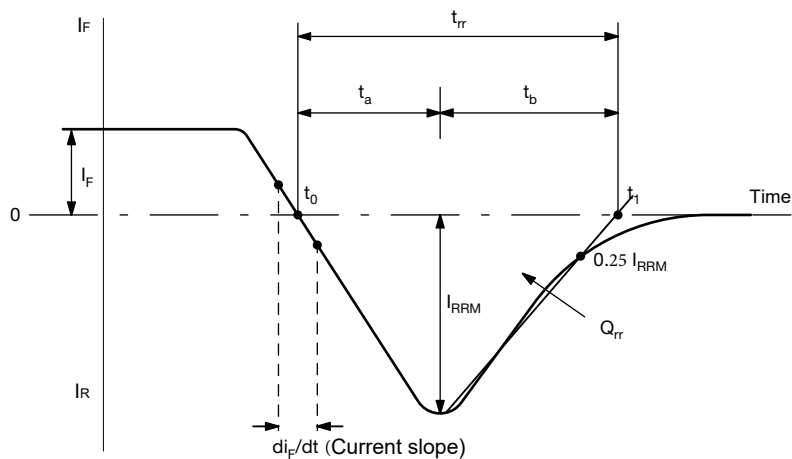

Reverse Recovery Waveform and Definitions

Typical Characteristics

Forward Characteristics

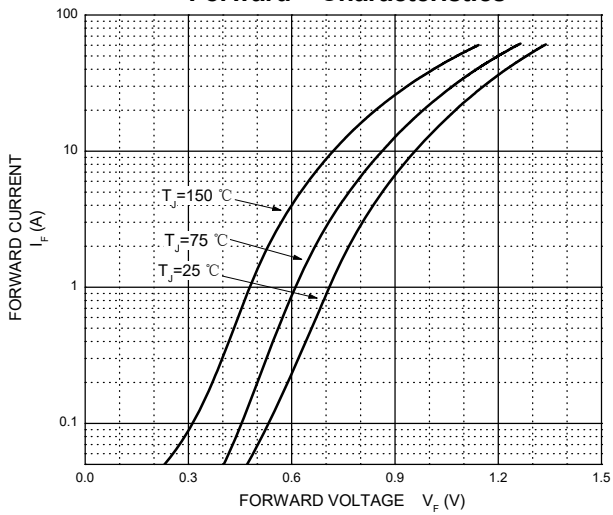

Reverse Characteristics

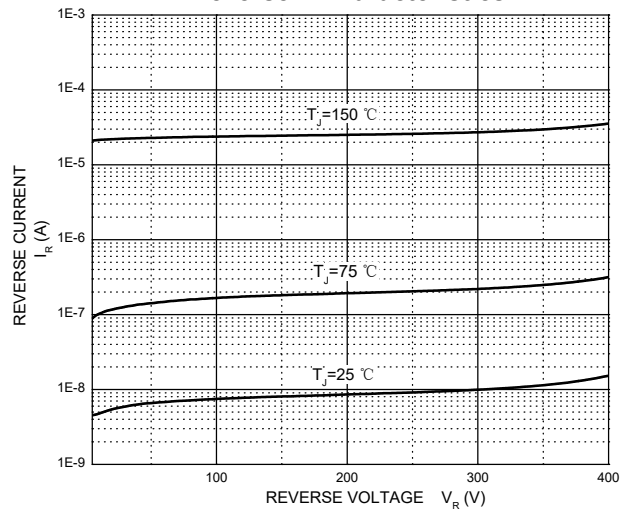

Capacitance Characteristics Per Diode

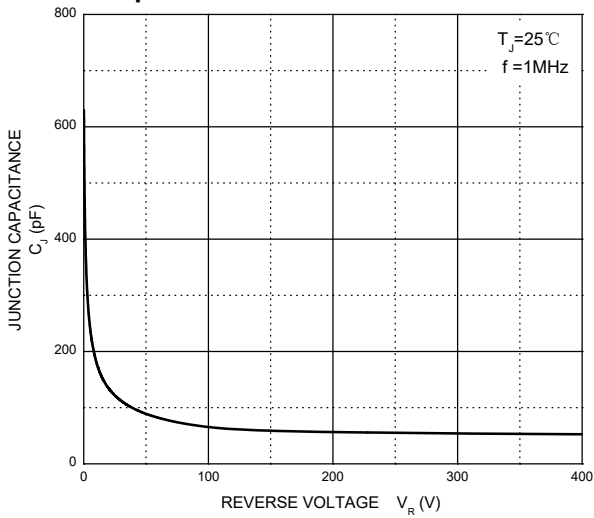

Recovery Current vs. di_F/dt

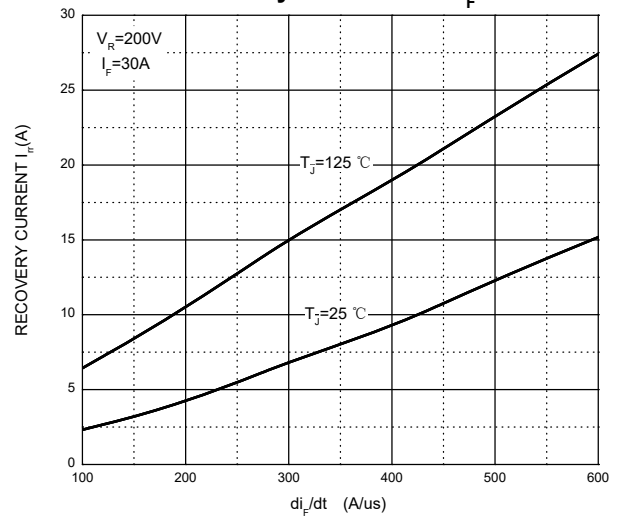

Reverse Recovery Time vs. di_F/dt

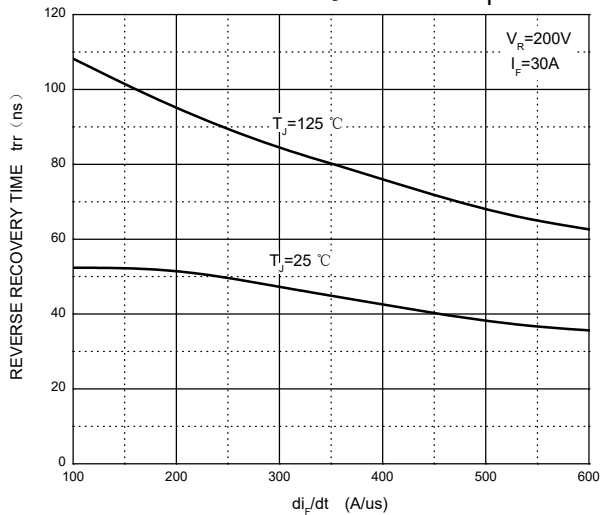

Stored Charge vs. di_F/dt

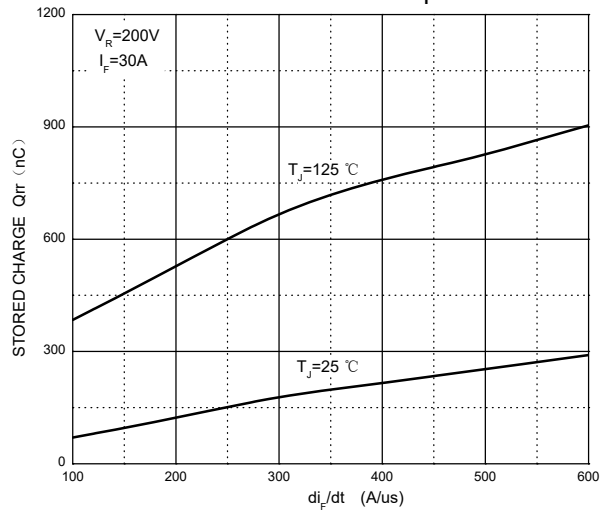

Typical Characteristics

Dynamic Parameters vs. Junction Temperature

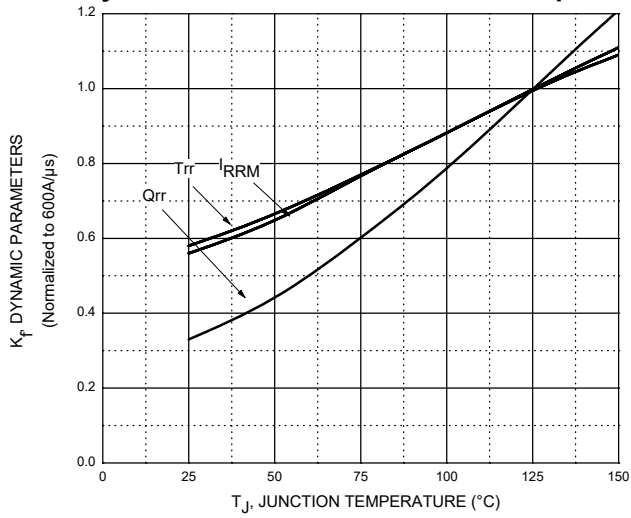

Current Derating

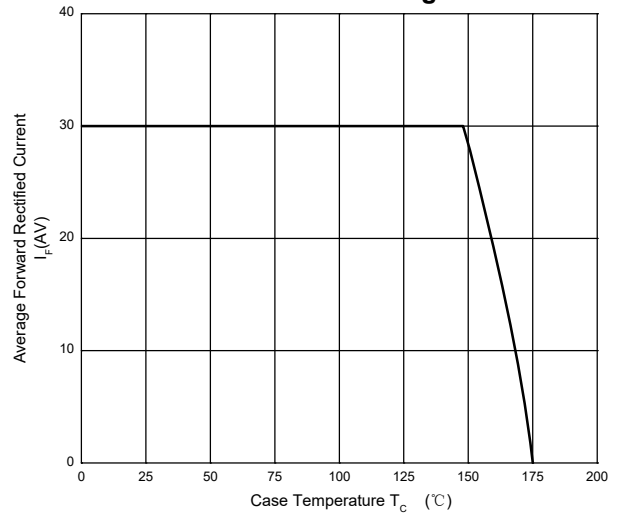

MURW60H40LCTB Transient Thermal Impedance, Junction-Case

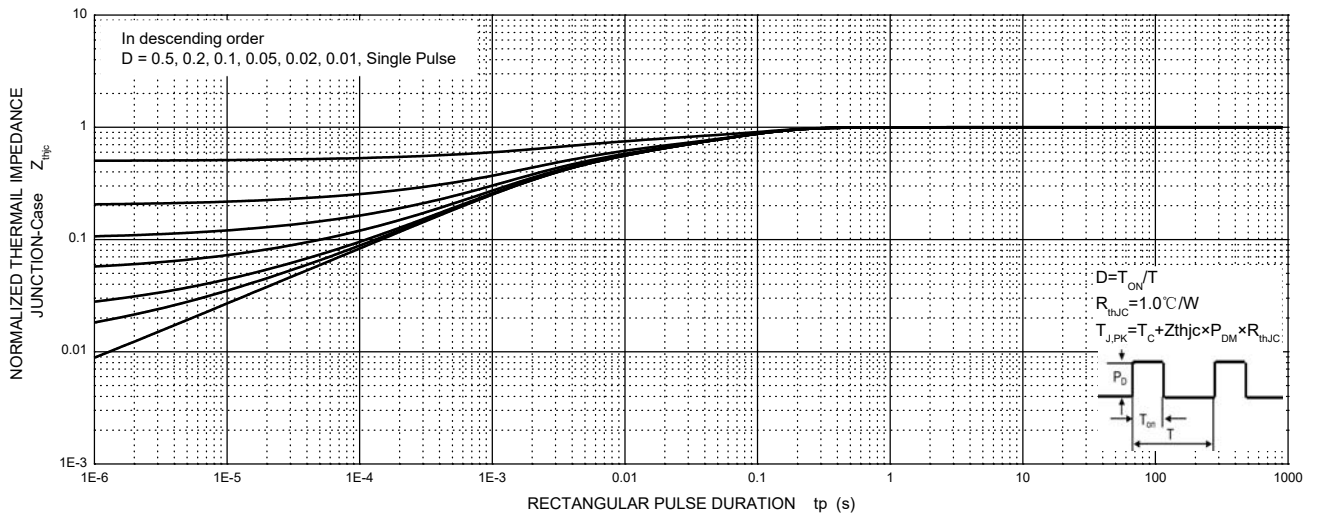

TO-247 Package Outline Dimensions

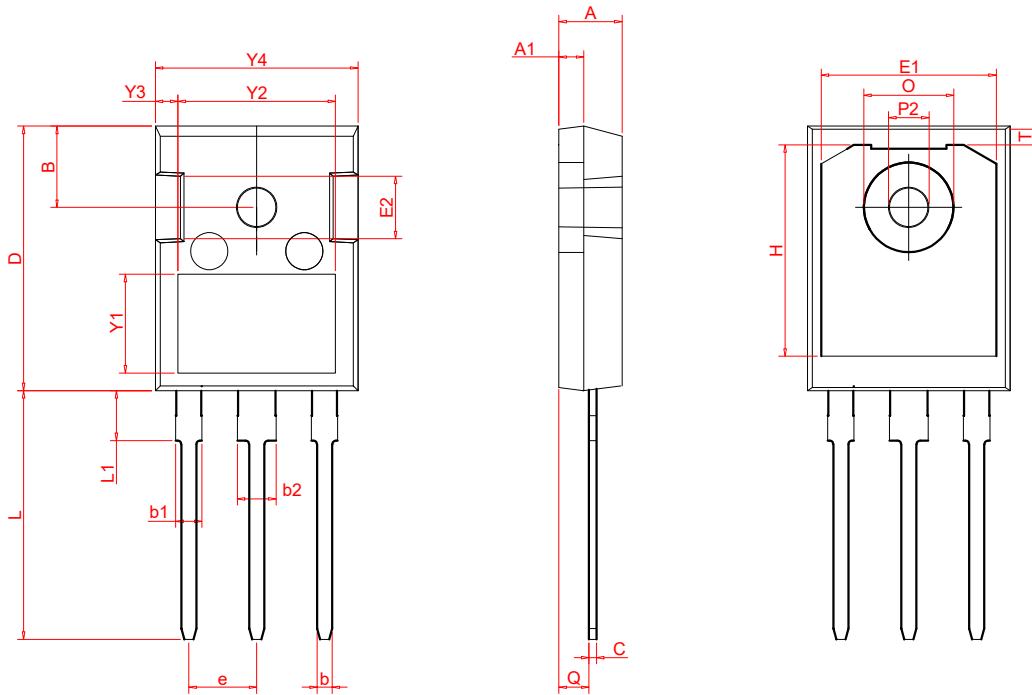

Symbol	Dimensions In Millimeters		Dimensions In Inches	
	Min	Max	Min	Max
A	4.700	5.300	0.185	0.209
A1	1.700	2.300	0.067	0.091
C	0.450	0.750	0.018	0.030
Q	2.200	2.600	0.087	0.102
O	7.100	7.400	0.280	0.291
P2	3.450	3.750	0.136	0.148
L	19.000	21.000	0.748	0.827
L1	4.2	4.5	0.165	0.177
b	1.000	1.400	0.039	0.055
b1	1.800	2.250	0.071	0.089
b2	3.000	3.300	0.118	0.130
e	5.250	5.550	0.207	0.219
D	20.950	21.350	0.825	0.841
Y1	7.600	8.100	0.299	0.319
Y2	11.000	13.000	0.433	0.512
Y3	1.750	2.250	0.069	0.089
Y4	16.000	16.400	0.630	0.646
E2	4.600	4.900	0.181	0.193
T	1.35REF		0.053REF	
H	16.25REF		0.639REF	
E1	14REF		0.551REF	
B	6.55REF		0.257REF	