

## DO-41 Pstic-Encapsulate Diodes

### SB1150 Schottky Rectifier Diode

#### Features

- $I_{F(AV)}$  1A
- $V_{RRM}$  150V
- High surge current capability
- Polarity: Color band denotes cathode
- Low peak forward voltage

#### Applications

- Rectifier

#### Marking

- SB1150

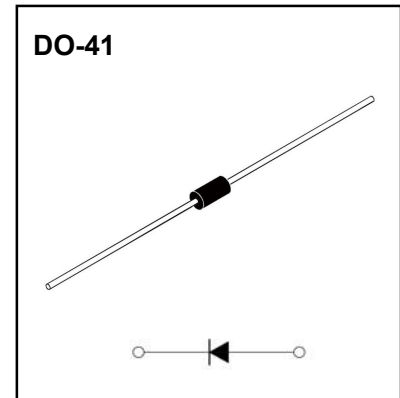

#### Limiting Values(Absolute Maximum Rating)

| Item                                 | Symbol      | Unit             | Test Conditions   | SB1150     |
|--------------------------------------|-------------|------------------|---|------------|
| Repetitive Peak Reverse Voltage      | $V_{RRM}$   | V                |   | 150        |
| Maximum RMS Voltage                  | $V_{RMS}$   | V                |   | 105        |
| Maximum DC Blocking Voltage          | $V_{DC}$    | V                |   | 150        |
| Average Forward Current              | $I_{F(AV)}$ | A                | 60Hz Half-sine wave, Resistance load, $T_L=100^\circ\text{C}$ | 1.0        |
| Surge(Non-repetitive)Forward Current | $I_{FSM}$   | A                | 60Hz Half-sine wave ,1 cycle ,<br>$T_a=25^\circ\text{C}$      | 40         |
| Junction Temperature                 | $T_J$       | $^\circ\text{C}$ |   | -55 ~ +150 |
| Storage Temperature                  | $T_{STG}$   | $^\circ\text{C}$ |   | -55 ~ +150 |

#### Electrical Characteristics (T=25 $^\circ\text{C}$ Unless otherwise specified)

| Item                         | Symbol           | Unit                      | Test Condition  | SB1150                  |     |
|------------------------------|------------------|---------------------------|---|-------------------------|-----|
| Maximum Peak Forward Voltage | $V_{FM}$         | V                         | $I_{FM}=1.0\text{A}$                                      | 0.85                    |     |
| Maximum Peak Reverse Current | $I_{RRM1}$       | mA                        | $V_{RM}=V_{RRM}$  | $T_a=25^\circ\text{C}$  | 0.2 |
|                              | $I_{RRM2}$       |                           |   | $T_a=100^\circ\text{C}$ | 2.0 |
| Typical junction capacitance | $C_J$            | pF                        | Measured at 1MHz and applied reverse voltage of 4.0V D.C. | 80                      |     |
| Typical Thermal Resistance   | $R_{\theta J-A}$ | $^\circ\text{C}/\text{W}$ | Between junction and ambient                              | 50                      |     |
|                              | $R_{\theta J-L}$ |                           | Between junction and lead                                 | 10                      |     |

# Typical Characteristics

FIG.1: FORWARD CURRENT DERATING CURVE

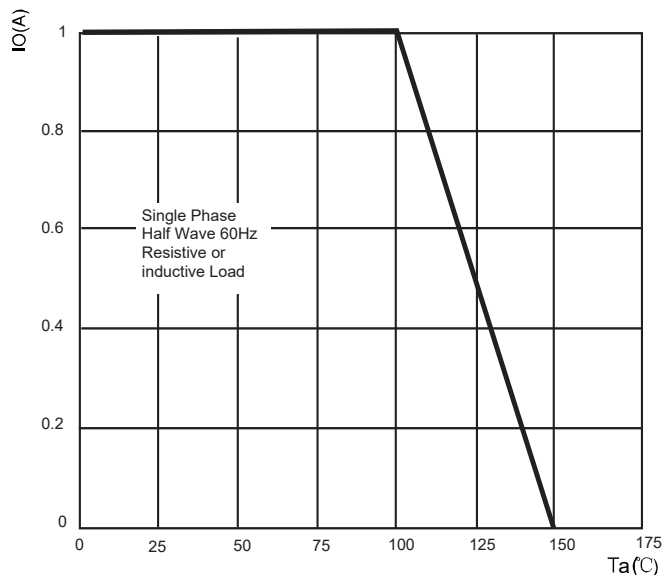

FIG.2: MAXIMUM NON-REPETITIVE FORWARD SURGE CURRENT

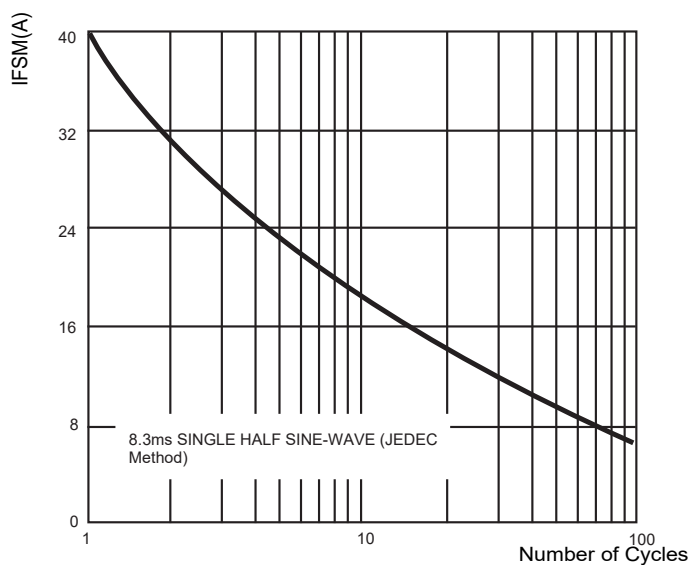

FIG.3: TYPICAL FORWARD CHARACTERISTICS

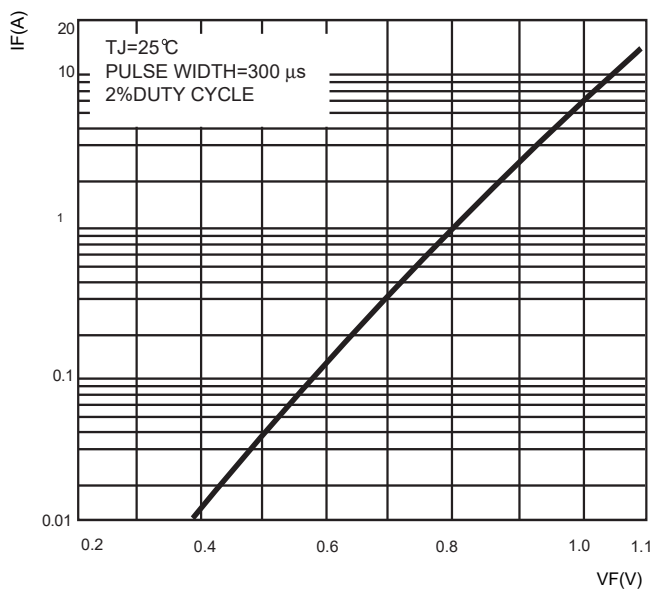
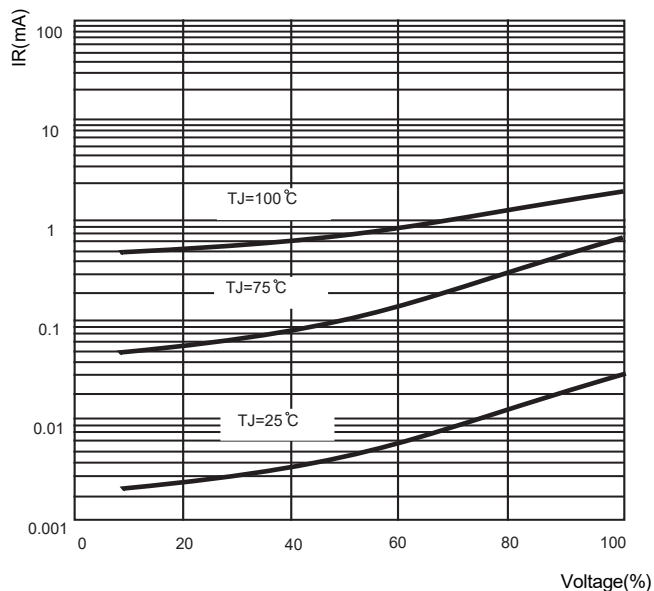
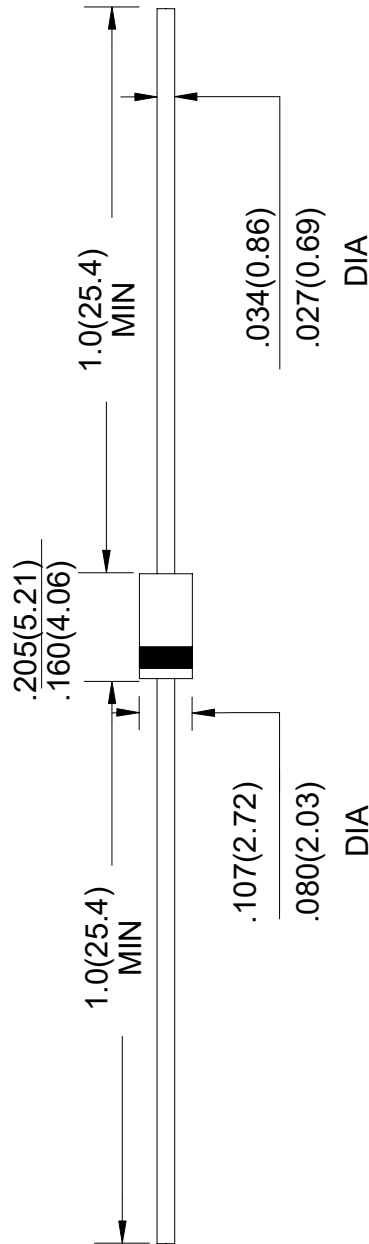

FIG.4: TYPICAL REVERSE CHARACTERISTICS





Unit: in inches (millimeters)

NOTICE

JSCJ reserves the right to make modifications, enhancements, improvements, corrections or other changes without further notice to any product herein. JSCJ does not assume any liability arising out of the application or use of any product described herein.

# Ammo Box Packaging Specifications For Axial Lead Rectifiers

Axial lead devices are packed in accordance with EIA standard RS-296-D and specifications given below

| COMPONENT OUTLINE | COMPONENT PITCH A          | INNER TAPE PITCH B      | CUMULATIVE PITCH TOLERANCE |
|-------------------|----------------------------|-------------------------|----------------------------|
|                   | $\pm 0.5\text{mm}(.020'')$ | $+0.5\text{mm}(.020'')$ |                            |
| R-1               | 5.0mm                      | 26.0mm                  | 2.0mm/20pitch              |
| R-1               | 5.0mm                      | 52.4mm                  | 2.0mm/10pitch              |
| A-405             | 5.0mm                      | 26.0mm                  | 2.0mm/20pitch              |
| A-405             | 5.0mm                      | 52.4mm                  | 2.0mm/10pitch              |
| DO-34/DO-35       | 5.0mm                      | 26.0mm                  | 2.0mm/20pitch              |
| DO-34/DO-35       | 5.0mm                      | 52.4mm                  | 2.0mm/10pitch              |
| DO-41             | 5.0mm                      | 26.0mm                  | 2.0mm/20pitch              |
| DO-41             | 5.0mm                      | 52.4mm                  | 2.0mm/10pitch              |
| DO-15             | 5.0mm                      | 52.4mm                  | 2.0mm/10pitch              |
| DO-27             | 10.0mm                     | 52.4mm                  | 2.0mm/10pitch              |
| R-6               | 10.0mm                     | 52.4mm                  | 2.0mm/10pitch              |

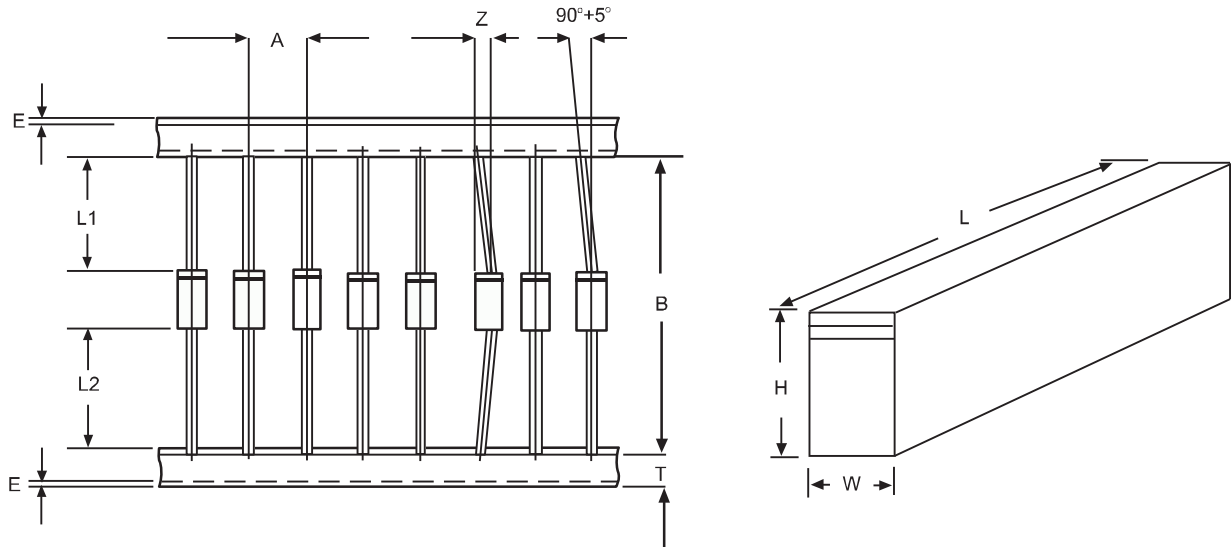

| ITEM                | SYMBOL    | SPECIFICATIONS(mm) | SPECIFICATIONS(inch) |
|---------------------|-----------|--------------------|----------------------|
| Component alignment | Z         | 1.2max             | 0.048max             |
| Tape width          | T         | $6.0\pm 0.4$       | $0.236\pm 0.016$     |
| Exposed adhesive    | E         | 0.8max             | 0.032max             |
| Body eccentricity   | $ L1-L2 $ | 1.0max             | 0.040max             |
| Box length          | L         | $255.0\pm 5.0$     | $10.04\pm 0.197$     |
| Box width           | W         | $78.0\pm 5.0$      | $3.07\pm 0.197$      |
| Box height          | H         | $150.0\pm 5.0$     | $5.91\pm 0.197$      |

NOTE: Each component lead shall be sandwiched between tapes for A minimum of 3.2mm(0.126'')