



## DO-15 Plastic-Encapsulate Diodes

### SB220 THRU SB2100 Schottky Rectifier Diodes

#### Features

- $I_{F(AV)}$  2A
- $V_{RRM}$  20V-100V
- High surge current capability
- Polarity: Color band denotes cathode

#### Applications

- Rectifier

#### Marking

- SB2XX
- X : From 20 To 100

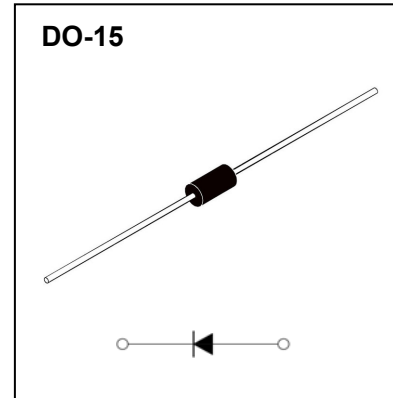

#### Limiting Values(Absolute Maximum Rating)

Item	Symbol	Unit	Test Conditions	SB2						
				20	30	40	50	60	80	100
Repetitive Peak Reverse Voltage	$V_{RRM}$	V		20	30	40	50	60	80	100
Maximum RMS Voltage	$V_{RMS}$	V		14	21	28	35	42	56	70
Maximum DC Blocking Voltage	$V_{DC}$	V		20	30	40	50	60	80	100
Average Forward Current	$I_{F(AV)}$	A	60Hz Half-sine wave, Resistance load, $T_L$ (Fig.1)	2.0						
Surge(Non-repetitive)Forward Current	$I_{FSM}$	A	60Hz Half-sine wave, 1 cycle, $T_a=25^\circ\text{C}$	60						
Junction Temperature	$T_J$	$^\circ\text{C}$		-55 ~ +125			-55 ~ +150			
Storage Temperature	$T_{STG}$	$^\circ\text{C}$		-55 ~ +150						

#### Electrical Characteristics (T=25 $^\circ\text{C}$ Unless otherwise specified)

Item	Symbol	Unit	Test Condition	SB2						
				20	30	40	50	60	80	100
Maximum Peak Forward Voltage	$V_F$	V	$I_F=2.0\text{A}$	0.55		0.7		0.85		
Maximum Peak Reverse Current	$I_{RRM1}$	mA	$V_{RM}=V_{RRM}$	$T_a=25^\circ\text{C}$						
	$I_{RRM2}$			$T_a=125^\circ\text{C}$						
Typical junction capacitance	$C_J$	pF	Measured at 1MHz and applied reverse voltage of 4.0V D.C.	220			80			
Typical Thermal Resistance	$R_{\theta J-A}$	$^\circ\text{C}/\text{W}$	Between junction and ambient	50						
	$R_{\theta J-L}$		Between junction and terminal	25						

# Typical Characteristics

FIG.1: FORWARD CURRENT DERATING CURVE

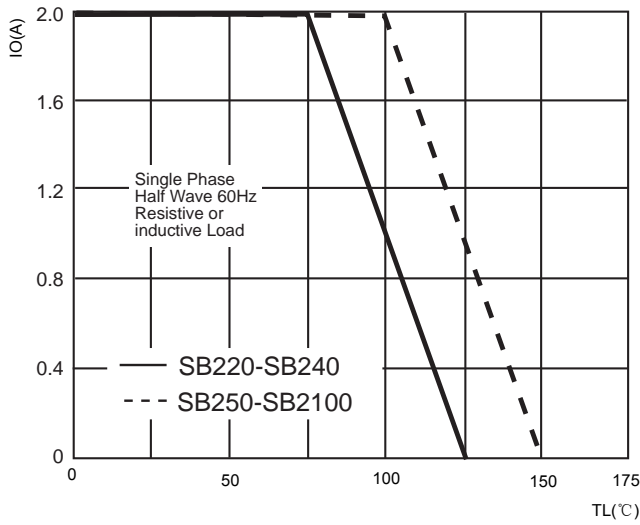

FIG.2: MAXIMUM NON-REPETITIVE FORWARD SURGE CURRENT

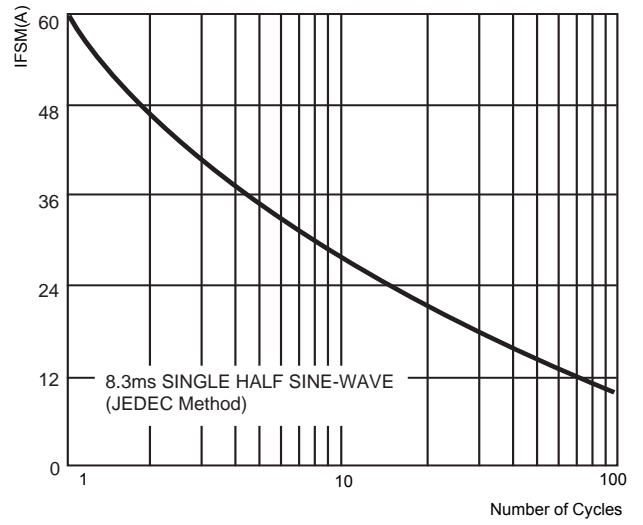

FIG.3: TYPICAL FORWARD CHARACTERISTICS

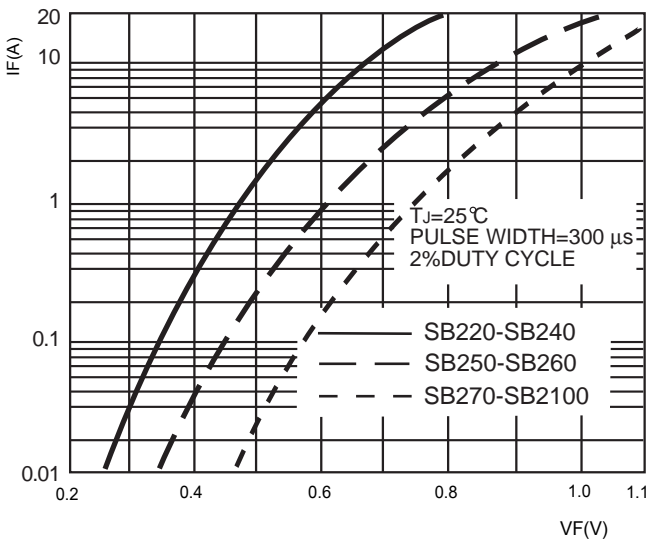
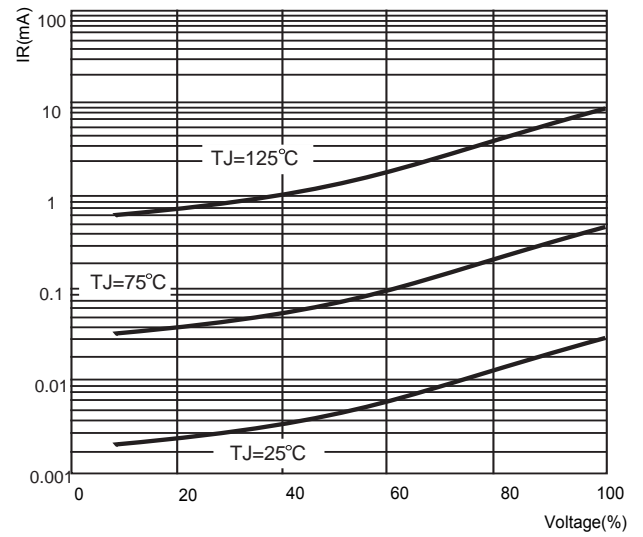
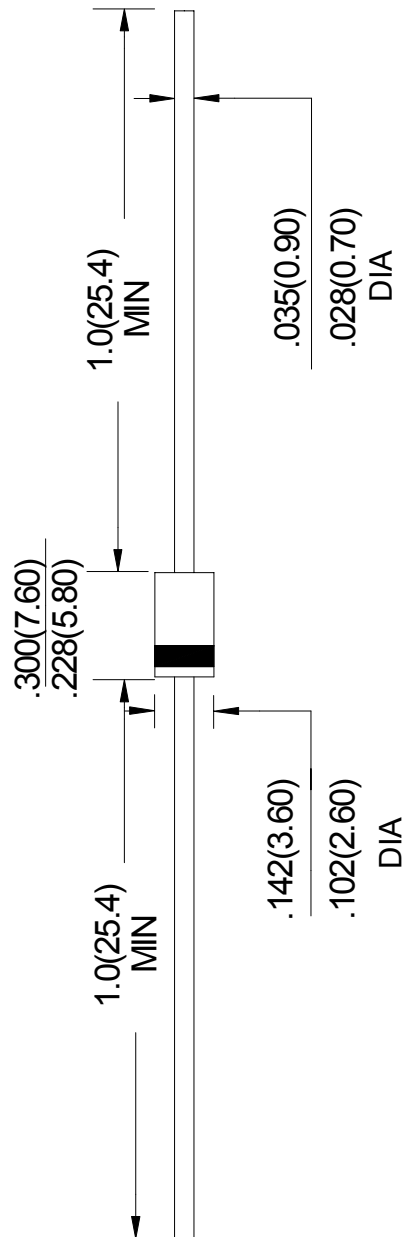

FIG.4: TYPICAL REVERSE CHARACTERISTICS



## DO-15 Package Outline Dimensions



Unit: in inches (millimeters)

### NOTICE

JSCJ reserves the right to make modifications, enhancements, improvements, corrections or other changes without further notice to any product herein. JSCJ does not assume any liability arising out of the application or use of any product described herein.

# Ammo Box Packaging Specifications For Axial Lead Rectifiers

Axial lead devices are packed in accordance with EIA standard RS-296-D and specifications given below

COMPONENT OUTLINE	COMPONENT PITCH A	INNER TAPE PITCH B	CUMULATIVE PITCH TOLERANCE
	$\pm 0.5\text{mm}(.020'')$	$+0.5\text{mm}(.020'')$	
R-1	5.0mm	26.0mm	2.0mm/20pitch
R-1	5.0mm	52.4mm	2.0mm/10pitch
A-405	5.0mm	26.0mm	2.0mm/20pitch
A-405	5.0mm	52.4mm	2.0mm/10pitch
DO-34/DO-35	5.0mm	26.0mm	2.0mm/20pitch
DO-34/DO-35	5.0mm	52.4mm	2.0mm/10pitch
DO-41	5.0mm	26.0mm	2.0mm/20pitch
DO-41	5.0mm	52.4mm	2.0mm/10pitch
DO-15	5.0mm	52.4mm	2.0mm/10pitch
DO-27	10.0mm	52.4mm	2.0mm/10pitch
R-6	10.0mm	52.4mm	2.0mm/10pitch

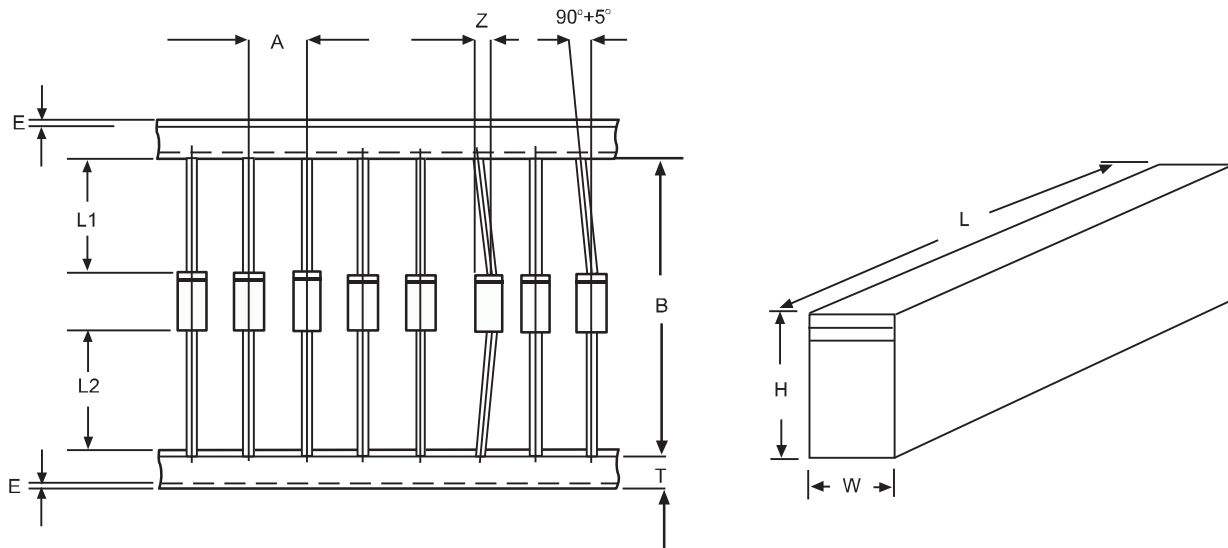

ITEM	SYMBOL	SPECIFICATIONS(mm)	SPECIFICATIONS(inch)
Component alignment	Z	1.2max	0.048max
Tape width	T	$6.0\pm 0.4$	$0.236\pm 0.016$
Exposed adhesive	E	0.8max	0.032max
Body eccentricity	IL1-L2I	1.0max	0.040max
Box length	L	$255.0\pm 5.0$	$10.04\pm 0.197$
Box width	W	$78.0\pm 5.0$	$3.07\pm 0.197$
Box height	H	$150.0\pm 5.0$	$5.91\pm 0.197$

NOTE: Each component lead shall be sandwiched between tapes for A minimum of 3.2mm(0.126'')