

DO-27 Plastic-Encapsulate Diodes

SB520L THRU SB5100L

Schottky Rectifier Diode

Features

- $I_{F(AV)}$ 5A
- V_{RRM} 20V~100V
- High surge current capability
- Polarity: Color band denotes cathode
- Low peak forward voltage

Applications

- Rectifier

Marking

- SB5XXL
XX:From 20 To 100

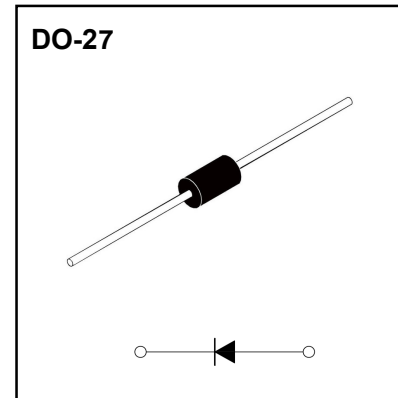

Limiting Values(Absolute Maximum Rating)

Item	Symbol	Unit	Test Conditions	SB5 20L	SB5 30L	SB5 40L	SB5 50L	SB5 60L	SB5 80L	SB5 100L
Repetitive Peak Reverse Voltage	V_{RRM}	V		20	30	40	50	60	80	100
Maximum RMS Voltage	V_{RMS}	V		14	21	28	35	42	56	70
Maximum DC Blocking Voltage	V_{DC}	V		20	30	40	50	60	80	100
Average Forward Current	$I_{F(AV)}$	A	60Hz Half-sine wave, Resistance load, $T_a=100^\circ\text{C}$	5.0						
Surge(Non-repetitive)Forward Current	I_{FSM}	A	60Hz Half-sine wave, 1 cycle, $T_a=25^\circ\text{C}$	150						
Junction Temperature	T_J	$^\circ\text{C}$		-55 ~ +125			-55 ~ +150			
Storage Temperature	T_{STG}	$^\circ\text{C}$		-55 ~ +150						

Electrical Characteristics (T=25 $^\circ\text{C}$ Unless otherwise specified)

Item	Symbol	Unit	Test Condition		SB5 20L	SB5 30L	SB5 40L	SB5 50L	SB5 60L	SB5 80L	SB5 100L
Maximum Peak Forward Voltage	V_F	V	$I_F=5.0\text{A}$	$T_a=25^\circ\text{C}$	0.45			0.50	0.70		
Maximum Peak Reverse Current	I_{RRM1}	mA	$V_{RM}=V_{RRM}$	$T_a=25^\circ\text{C}$	0.3				0.02		
	I_{RRM2}			$T_a=125^\circ\text{C}$	50				20		
Typical junction capacitance	C_J	pF	Measured at 1MHz and applied reverse voltage of 4.0V D.C.		500			400			
Typical Thermal Resistance	$R_{\theta J-A}$	$^\circ\text{C}/\text{W}$	Between junction and ambient		25						
	$R_{\theta J-L}$		Between junction and lead		5						

Notes:

Thermal resistance from junction to ambient at 0.375"(9.5mm)lead length,P.C.B. mounted

Typical Characteristics

FIG.1: FORWARD CURRENT DERATING CURVE

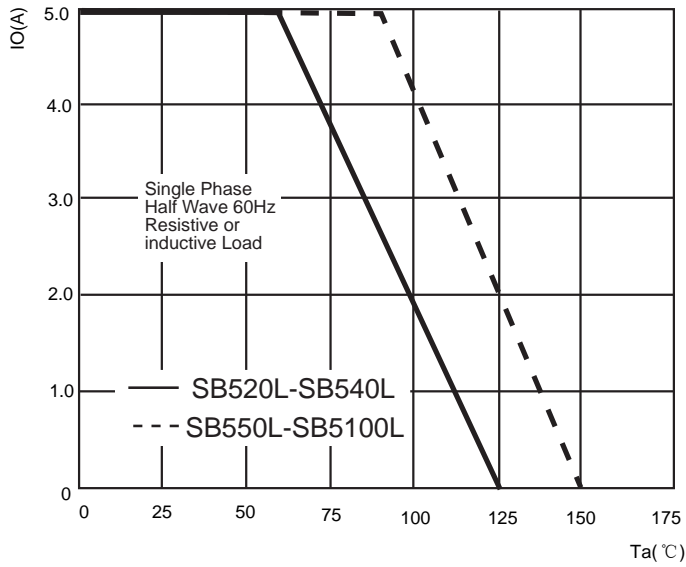

FIG.2: MAXIMUM NON-REPETITIVE FORWARD SURGE CURRENT

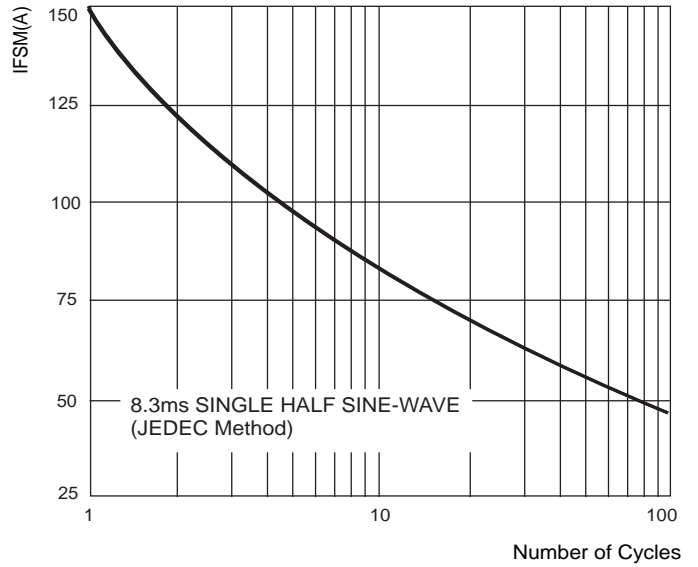

FIG.3: TYPICAL FORWARD CHARACTERISTICS

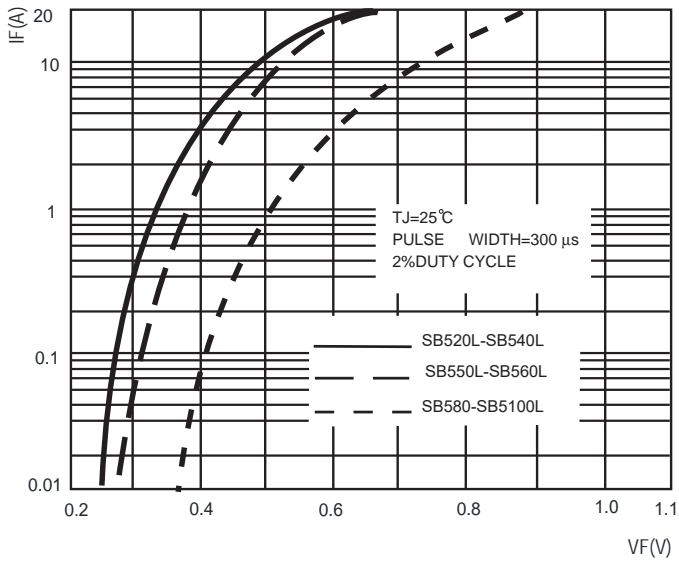
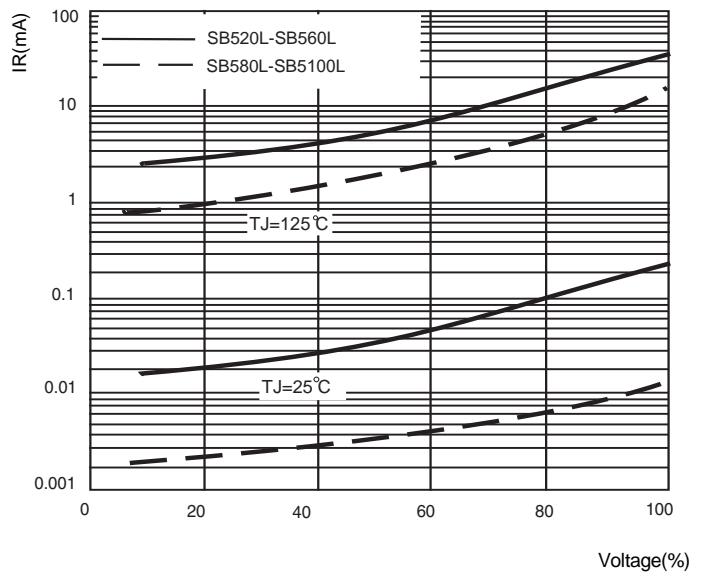
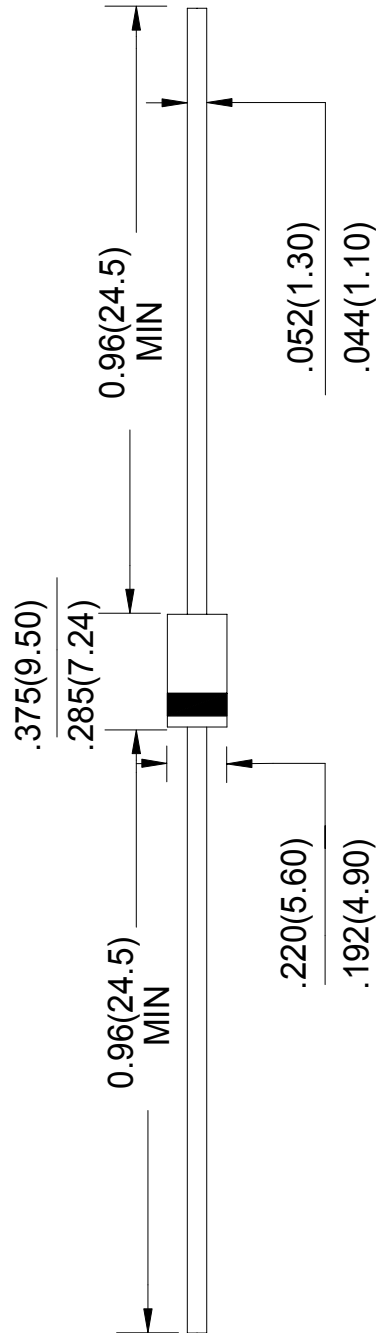

FIG.4: TYPICAL REVERSE CHARACTERISTICS



DO-27 Package Outline Dimensions



Unit: in inches (millimeters)

NOTICE

JSCJ reserves the right to make modifications, enhancements, improvements, corrections or other changes without further notice to any product herein. JSCJ does not assume any liability arising out of the application or use of any product described herein.

Ammo Box Packaging Specifications For Axial Lead Rectifiers

Axial lead devices are packed in accordance with EIA standard RS-296-D and specifications given below

COMPONENT OUTLINE	COMPONENT PITCH A	INNER TAPE PITCH B	CUMULATIVE PITCH TOLERANCE
	$\pm 0.5\text{mm}(.020'')$	$+0.5\text{mm}(.020'')$	
R-1	5.0mm	26.0mm	2.0mm/20pitch
R-1	5.0mm	52.4mm	2.0mm/10pitch
A-405	5.0mm	26.0mm	2.0mm/20pitch
A-405	5.0mm	52.4mm	2.0mm/10pitch
DO-34/DO-35	5.0mm	26.0mm	2.0mm/20pitch
DO-34/DO-35	5.0mm	52.4mm	2.0mm/10pitch
DO-41	5.0mm	26.0mm	2.0mm/20pitch
DO-41	5.0mm	52.4mm	2.0mm/10pitch
DO-15	5.0mm	52.4mm	2.0mm/10pitch
DO-27	10.0mm	52.4mm	2.0mm/10pitch
R-6	10.0mm	52.4mm	2.0mm/10pitch

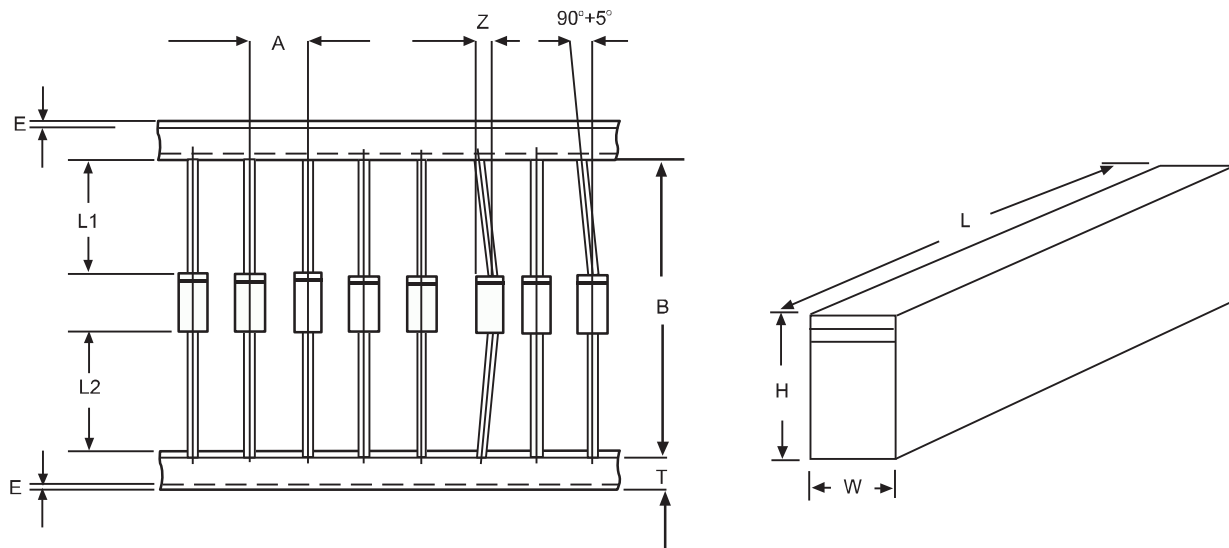

ITEM	SYMBOL	SPECIFICATIONS(mm)	SPECIFICATIONS(inch)
Component alignment	Z	1.2max	0.048max
Tape width	T	6.0 ± 0.4	0.236 ± 0.016
Exposed adhesive	E	0.8max	0.032max
Body eccentricity	$ L1-L2 $	1.0max	0.040max
Box length	L	255.0 ± 5.0	10.04 ± 0.197
Box width	W	78.0 ± 5.0	3.07 ± 0.197
Box height	H	150.0 ± 5.0	5.91 ± 0.197

NOTE: Each component lead shall be sandwiched between tapes for A minimum of 3.2mm(0.126'')