

## TO-247 Plastic-Encapsulate Diode

### SBDW60H200CTB SCHOTTKY BARRIER RECTIFIER

#### MAIN CHARACTERISTICS

$I_o$	<b>60 (2×30) A</b>
$V_{RRM}$	<b>200 V</b>
$T_j$	<b>175 °C</b>
$V_{F(typ)}$	<b>0.71V (@<math>T_j=150^{\circ}C</math>)</b>

#### FEATURES

- Low Power Loss,High Efficiency
- Guard Ring Die Construction for Transient Protection
- High Current Capability and Low Forward Voltage Drop

#### MARKING

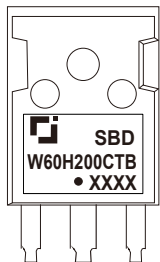

SBDW60200CTB = Device code  
 Solid dot = Green molding compound device  
 if none, the normal device  
 XXXX = Code

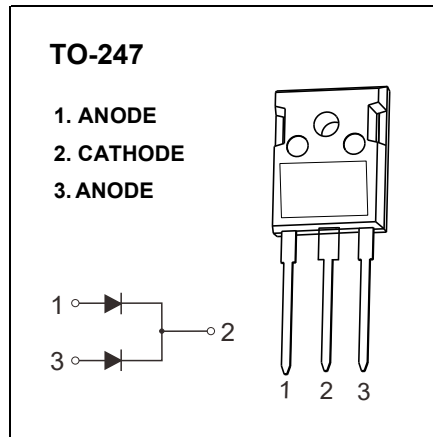

#### MAXIMUM RATINGS ( $T_a=25^{\circ}C$ unless otherwise noted )

Symbol	Parameter	Value	Unit
$V_{RRM}$	Peak repetitive reverse voltage	200	V
$V_{RWM}$	Working peak reverse voltage		
$V_R$	DC blocking voltage		
$V_{R(RMS)}$	RMS reverse voltage	140	V
$I_o$	Average rectified output current	60	A
$I_{FSM}$	Non-Repetitive peak forward surge current (8.3ms half sine wave)	450	A
$R_{\theta Jc}$	Thermal resistance from junction to case , $T_c=25^{\circ}C$	2.0	$^{\circ}C/W$
$R_{\theta JA}$	Thermal resistance from junction to ambient	62.5	$^{\circ}C/W$
$T_j$	Junction temperature	175	$^{\circ}C$
$T_{stg}$	Storage temperature	-55~+175	$^{\circ}C$

#### ELECTRICAL CHARACTERISTICS ( $T_a=25^{\circ}C$ unless otherwise specified)

Parameter	Symbol	Test conditions	Min	Typ	Max	Unit
Reverse voltage	$V_{(BR)}$	$I_R=1mA$	200			V
Reverse current	$I_R$	$V_R=200V$	$T_j = 25^{\circ}C$	100	500	nA
			$T_j = 150^{\circ}C$	2.0		mA
Forward voltage	$V_F$	$I_F=15A$	$T_j = 25^{\circ}C$	0.78		V
			$T_j = 150^{\circ}C$	0.62		V
		$I_F=30A$	$T_j = 25^{\circ}C$	0.85	0.90	V
			$T_j = 150^{\circ}C$	0.71		V

\*Pulse test: pulse width  $\leq 300\mu s$ , duty cycles  $\leq 2.0\%$ .

# Typical Characteristics

**Forward Current Derating Curve**

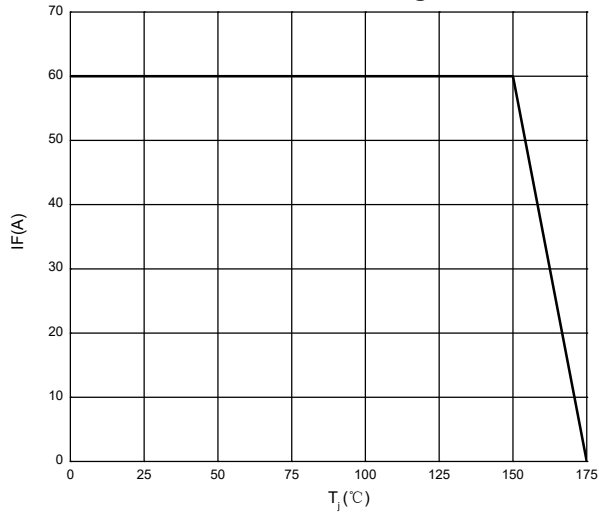

**Forward Characteristics**

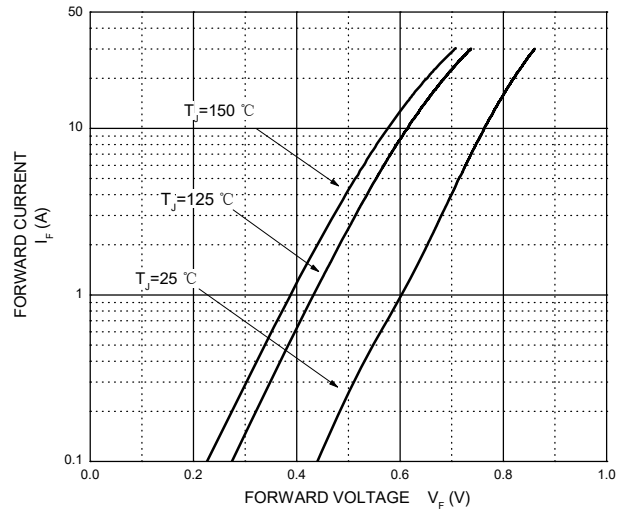

**Reverse Characteristics**

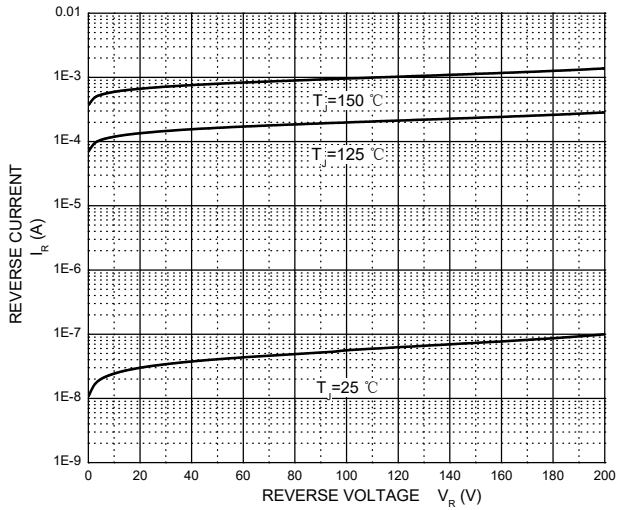

**Capacitance Characteristics Per Diode**

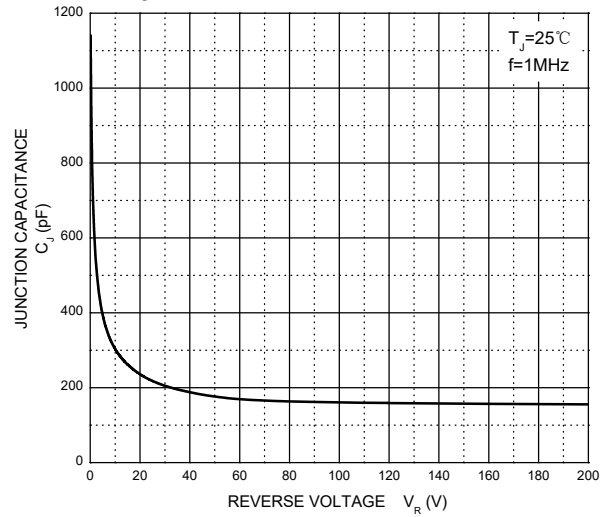

# TO-247 Package Outline Dimensions

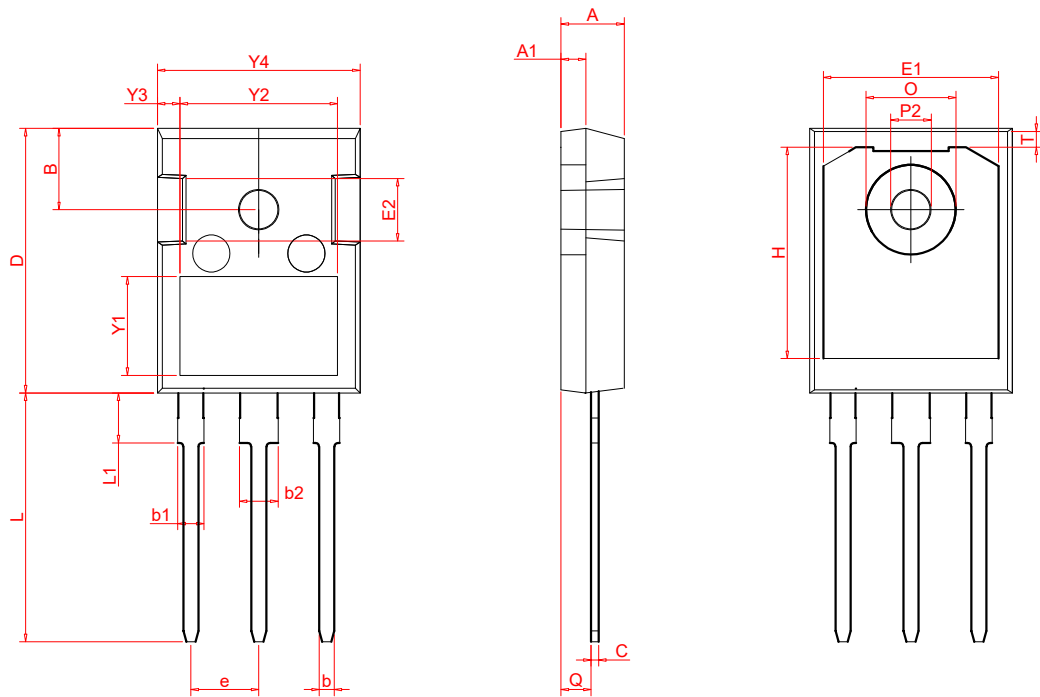

Symbol	Dimensions In Millimeters		Dimensions In Inches	
	Min	Max	Min	Max
A	4.700	5.300	0.185	0.209
A1	1.700	2.300	0.067	0.091
C	0.450	0.750	0.018	0.030
Q	2.200	2.600	0.087	0.102
O	7.100	7.400	0.280	0.291
P2	3.450	3.750	0.136	0.148
L	19.000	21.000	0.748	0.827
L1	4.2	4.5	0.165	0.177
b	1.000	1.400	0.039	0.055
b1	1.800	2.250	0.071	0.089
b2	3.000	3.300	0.118	0.130
e	5.250	5.550	0.207	0.219
D	20.950	21.350	0.825	0.841
Y1	7.600	8.100	0.299	0.319
Y2	11.000	13.000	0.433	0.512
Y3	1.750	2.250	0.069	0.089
Y4	16.000	16.400	0.630	0.646
E2	4.600	4.900	0.181	0.193
T	1.35REF		0.053REF	
H	16.25REF		0.639REF	
E1	14REF		0.551REF	
B	6.55REF		0.257REF	