

ULN2001 Darlington Transistor (NPN)

1 Introduction

ULN2001 is a high voltage, high current Darlington transistor array. Each device consists of three NPN Darlington pairs that can be output independently. The collector current of a single Darlington pair is rated at 500mA, and parallel Darlington pairs provide a higher current. Applications include relay drivers, lamp drivers, display drivers, line drivers, and logic buffers.

Each Darlington pair of ULN2001 devices has a 2.7kΩ series base resistance that works directly with TTL or CMOS devices. This device is often used to drive a variety of loads, such as DC engine, LED display light, high power cache and general logic circuits such as TTL, 5V CMOS, etc.

In addition, each Darlington pair input stage of the ULN2001 is designed with a 4kΩ pull-down resistor to ground, which can prevent load misoperation caused by the uncertain state of the single-chip microcomputer.

2 Available Package

PART NUMBER	PACKAGE
ULN2001-PAN	SOP8

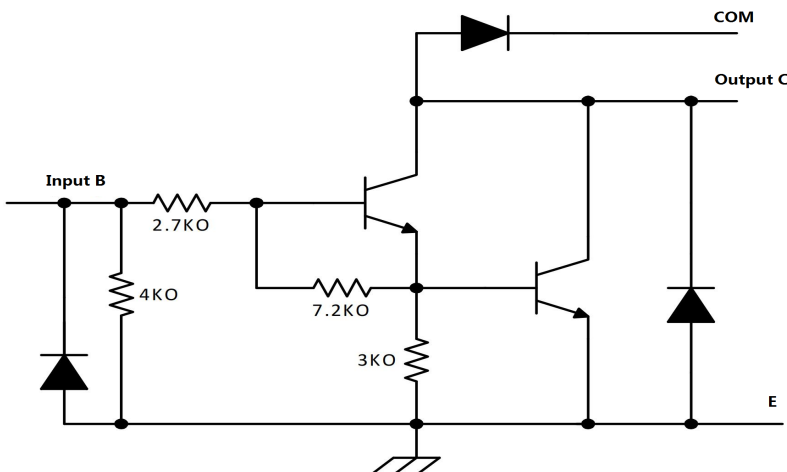

Figure 2-1. Functional Block Diagram

3 Features

- 500mA rated collector current (single output)
- High voltage output: 40V
- Output clamp diode
- Compatible with all kinds of logic input
- 4kΩ pull-down resistor

4 Applications

- Relay Drivers
- Lamp Drivers
- Line Drivers
- Logic Buffers
- Stepper Motors
- IP Camera
- HVAC Valve and LED Dot Matrix

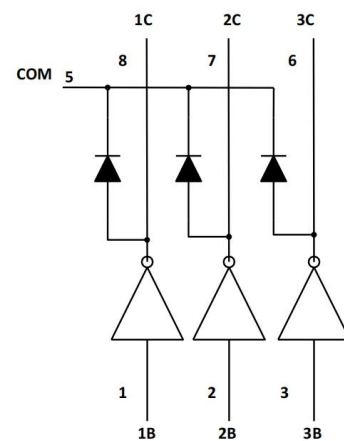

Figure 2-2. Simplified Block Diagram

5 Pin Configuration and Marking Information

5.1 Pin Configuration and Function

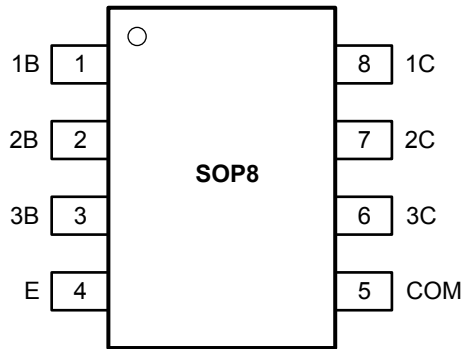
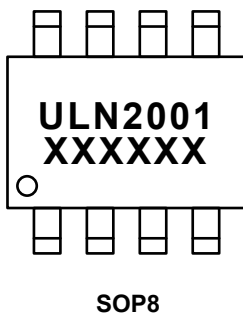

Figure 5-1. Pin Configuration (Top View)

PIN NAME	ULN2001-PAN	I / O	DESCRIPTION
	SOP8		
1B	1	I	Channel 1 through 3 Darlington base input
2B	2	I	
3B	3	I	
E	4	-	Common emitter shared by all channels (typically tied to ground)
COM	5	-	Common cathode node for flyback diodes (required for inductive loads)
3C	6	O	Channel 1 through 3 Darlington collector output
2C	7	O	
1C	8	O	

5.2 Marking Information



Note:

"ULN2001" = Device Number.

"XXXXXX" = Code, Indicates weekly record information of production.

6 Specifications

6.1 Absolute Maximum Ratings

at 25°C free-air temperature (unless otherwise specified)⁽¹⁾

CHARACTERISTIC			SYMBOL	VALUE	UNIT
Collector-emitter voltage ⁽²⁾			V_{CE}	40	V
Clamp diodes reverse voltage ⁽²⁾			V_{COM}	40	V
Input voltage ⁽²⁾			V_{IN}	30	V
Peak collector current			I_{CP}	500	mA
Output clamp current			I_{OK}	500	mA
Total emitter-terminal current			I_{TE}	-1	A
Maximum power dissipation	ULN2001	SOP8	$P_{D\ MAX}$	Internally Limited ⁽³⁾	W
Maximum junction temperature			$T_{J\ MAX}$	150	°C
Storage temperature			T_{stg}	-65 ~ 150	°C

(1) Stresses beyond those listed under *Absolute Maximum Ratings* may cause permanent damage to the device. These are stress ratings only, which do not imply functional operation of the device at these or any other conditions beyond those indicated under *Recommended Operating Conditions*. Exposure to absolute-maximum rated conditions for extended periods may affect device reliability.

(2) All voltages are with respect to network ground terminal.

(3) Refer to *Thermal Information* for details.

6.2 Recommended Operating Conditions

PARAMETER	SYMBOL	MIN.	NOM.	MAX.	UNIT
Operating junction temperature	T_J	-20	-	125	°C
Operating ambient temperature	T_A	-20	-	85	°C

6.3 ESD Ratings

ESD RATINGS		SYMBOL	VALUE	UNIT
Electrostatic discharge ⁽⁴⁾	Human body model	$V_{ESD-HBM}$	2000	V

(4) ESD testing is conducted in accordance with the relevant specifications formulated by the Joint Electronic Equipment Engineering Commission (JEDEC). The human body model (HBM) electrostatic discharge test is based on the JESD22-114D test standard, using a 100pF capacitor and discharging to each pin of the device through a resistance of 1.5kΩ.

6.4 Thermal Information

THERMAL METRIC ⁽⁵⁾		SYMBOL	SOP8	UNIT
Thermal resistance (Junction-to-ambient)		$R_{\theta JA}$	160	°C/W
Reference maximum power dissipation for continuous operation	$T_A=+25^\circ\text{C}$	$P_{D\ Ref}$	0.625	W
	$T_A=+85^\circ\text{C}$		0.25	

(5) $T_A = 25^\circ\text{C}$, measured on evaluation board with 1oz. copper traces of minimum pad size, all device outputs were active.

6 Specifications

6.5 Electrical Characteristics

Unless otherwise noted $T_A = 25^\circ\text{C}$.

PARAMETER	SYMBOL	TEST FIGURE	TEST CONDITIONS	MIN.	TYP. ⁽⁶⁾	MAX.	UNIT	
Input voltage (ON)	$V_{IN(ON)}$	Figure 3	$V_{CE} = 1.5\text{V}$	$I_C = 30\text{mA}$	-	1.5	2	V
				$I_C = 60\text{mA}$	-	1.6	2	
				$I_C = 120\text{mA}$	-	1.7	2.1	
				$I_C = 240\text{mA}$	-	1.9	2.2	
				$I_C = 350\text{mA}$	-	2.2	2.4	
			$I_I = 800\mu\text{A}$ ($V_{CE} < 1.5\text{V}$)	$I_C = 30\text{mA}$	-	2.3	2.7	
				$I_C = 60\text{mA}$	-	2.4	2.74	
				$I_C = 120\text{mA}$	-	2.5	2.8	
				$I_C = 240\text{mA}$	-	2.7	2.93	
			$I_I = 1\text{mA}$ ($V_{CE} < 1.5\text{V}$)	$I_C = 350\text{mA}$	-	2.9	3.08	
				$I_C = 30\text{mA}$	-	2.7	3.12	
				$I_C = 60\text{mA}$	-	2.8	3.17	
				$I_C = 120\text{mA}$	-	2.9	3.24	
				$I_C = 240\text{mA}$	-	3.1	3.4	
			Collector-emitter saturation voltage	$V_{CE(SAT)}$	Figure 4	$V_I = 2.4\text{V}$ ($I_I > 800\mu\text{A}$)	$I_C = 30\text{mA}$	
$I_C = 60\text{mA}$	-	0.8					-	
$I_C = 120\text{mA}$	-	0.9					-	
$I_C = 240\text{mA}$	-	1.2					-	
$I_C = 350\text{mA}$	-	1.4					-	
Input current	I_I	Figure 2	$I_C = 60\text{mA}$	$V_I = 12\text{V}$	-	5.7	-	mA
				$V_I = 6\text{V}$	-	2.7	-	
				$V_I = 4.5\text{V}$	-	1.9	-	
				$V_I = 2.4\text{V}$	-	0.8	-	
Clamp forward voltage	V_F	Figure 6	$I_F = 350\text{mA}$	-	1.6	2.0	V	
Collector cutoff current	I_{CEX}	Figure 1	$V_{CE} = 40\text{V}, I_I = 0$	-	-	50	μA	
Collector withstand voltage	V_{CE}	Figure 1	$V_{CE} = 40\text{V}, I_I = 0$	40	-	-	V	
Clamp diode reverse leakage current	I_R	Figure 5	$V_R = 40\text{V}$	-	-	50	μA	
Clamping diode reverse voltage	V_R	Figure 5	$V_R = 40\text{V}$	40	-	-	V	
Turn-on delay time	t_{PLH}	Figure 7	$V_L = 12\text{V}, R_L = 45\Omega$	-	0.15	1	μs	
Turn-off delay time	t_{PHL}	Figure 7	$V_L = 12\text{V}, R_L = 45\Omega$	-	0.15	1	μs	

Note:

(6) Typical numbers are at 25°C and represent the most likely norm.

7 Parameter Measurement Information

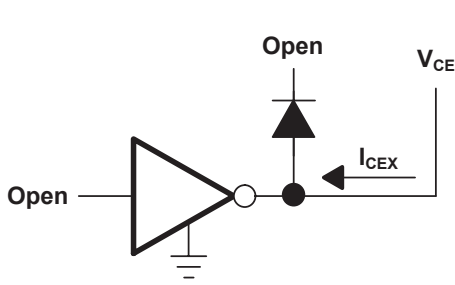

Figure 1. I_{CEX} Test Circuit

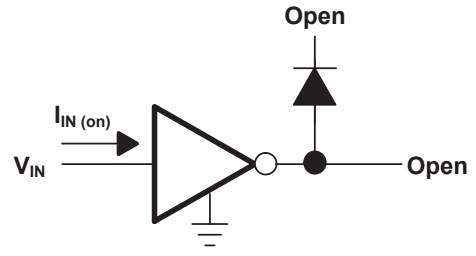

Figure 2. I_{IN} Test Circuit

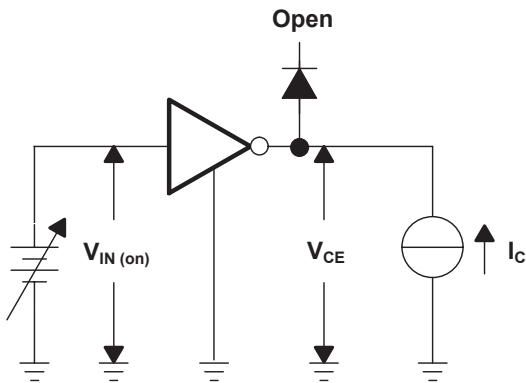

Figure 3. $V_{IN(on)}$ Test Circuit

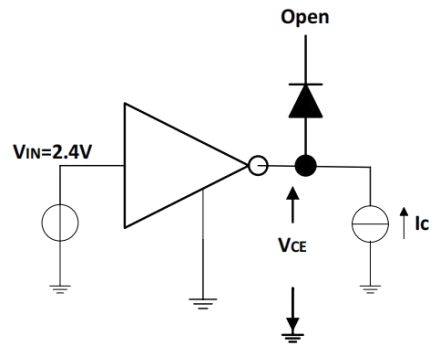

Figure 4. $V_{CE(SAT)}$ Test Circuit

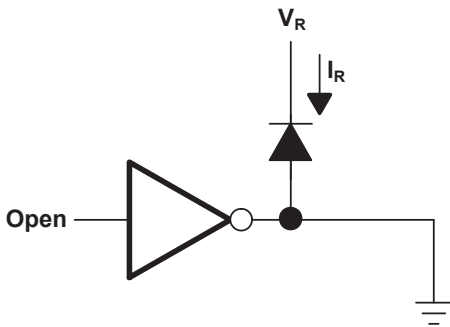

Figure 5. I_R Test Circuit

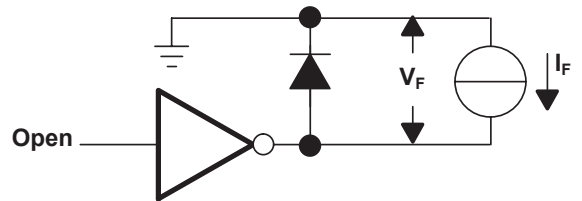
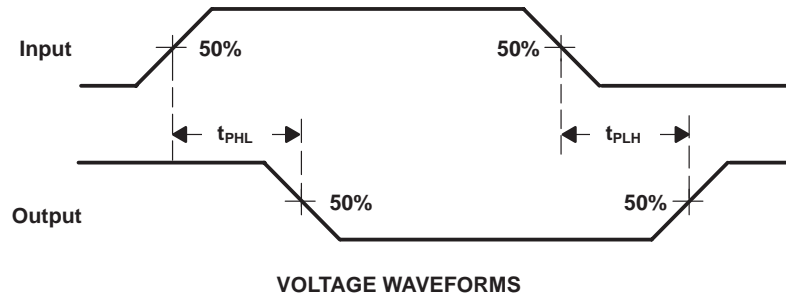

Figure 6. V_F Test Circuit

7 Parameter Measurement Information (continued)



VOLTAGE WAVEFORMS

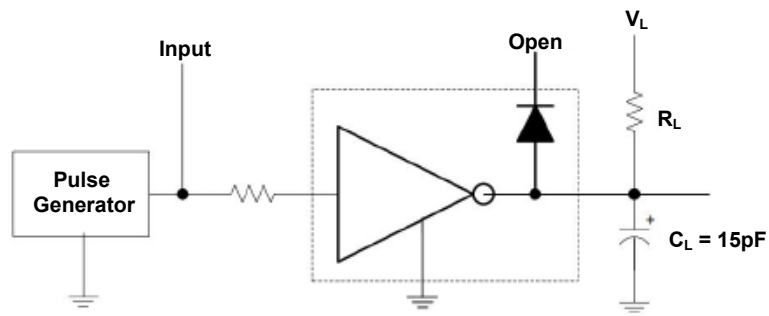

Figure 7. Propagation Delay-Time Waveforms

8 Typical Application

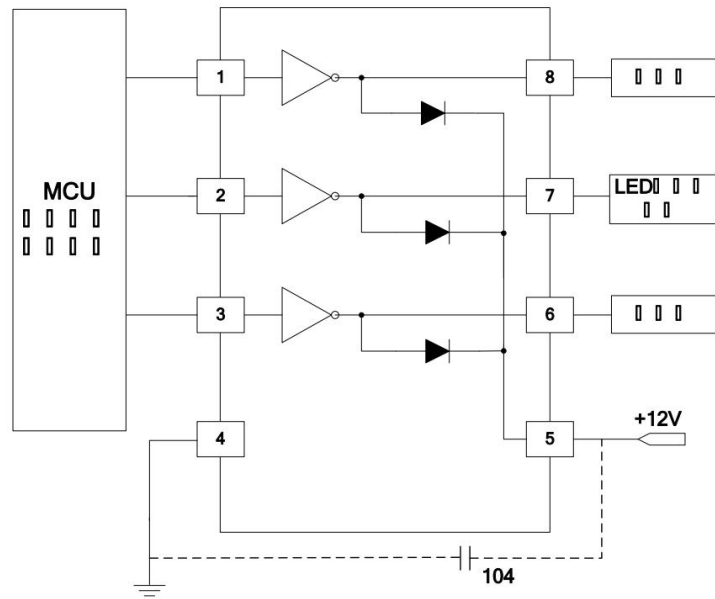

Figure 8-1. Typical application circuit

The applications of ULN2001 are not limited to the circuit diagram shown in Figure 8-1. Specifically, the driven load could be 3 relays, 3 LED diodes, or two outputs paralleled as one channel, depending on actual usage scenarios.

ULN2001 integrates 4kΩ pull-down resistors per channel, eliminating the need for external pull-down resistors. When using an RC buck circuit to power ULN2001, note that RC circuits cannot suppress transient voltage spikes from the power grid. A 104 capacitor must be connected between the COM terminal and ground near ULN2001, as illustrated in Figure 8-1. This capacitor is unnecessary in other application scenarios.

NOTE

The application information in this section is not part of the data sheet component specification, and JSCJ makes no commitment or statement to guarantee its accuracy or completeness. Customers are responsible for determining the rationality of corresponding components in their circuit design and making tests and verifications to ensure the normal realization of their circuit design.

9 Notes and Revision History

9.1 Associated Product Family and Others

To view other products of the same type or IC products of other types, please click the official website of JSCJ -- <https://www.jscj-elec.com> for more details.

9.2 Notes

Electrostatic Discharge Caution



This IC may be damaged by ESD. Relevant personnel shall comply with correct installation and use specifications to avoid ESD damage to the IC. If appropriate measures are not taken to prevent ESD damage, the hazards caused by ESD include but are not limited to degradation of integrated circuit performance or complete damage of integrated circuit. For some precision integrated circuits, a very small parameter change may cause the whole device to be inconsistent with its published specifications.

9.3 Revision History

September, 2025: released ULN2001 rev - 1.0.

10 Orderable, Mechanical, and Packaging Information

The following pages include mechanical packaging and orderable information. This information is the most current data available for the designated devices. This data is subject to change without notice and revision of this document. For browser based versions of this data sheet, refer to the left hand navigation.

Orderable Information

MODEL	DEVICE	PACKAGE	OP TEMP	ECO PLAN	MSL	PACKING OPTION	SORT
ULN2001	ULN2001-PAN	SOP8	-40 ~ 85°C	RoHS & Green	Level 3 168 HR	Tape and Reel 4000 Units / Reel	Active
Others	-	-	-	-	-	-	Customized

Note:

ECO PLAN: For the RoHS and Green certification standards of this product, please refer to the official report provided by JSCJ.

MSL: Moisture Sensitivity Level. Determined according to JEDEC industry standard classification.

SORT: Specifically defined as follows:

Active: Recommended for new products;

Customized: Products manufactured to meet the specific needs of customers;

Preview: The device has been released and has not been fully mass produced. The sample may or may not be available;

NoRD: It is not recommended to use the device for new design. The device is only produced for the needs of existing customers;

Obsolete: The device has been discontinued.

Mechanical Information

SOP8 Mechanical Information

Outline Dimensions

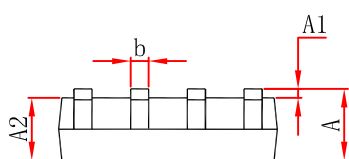
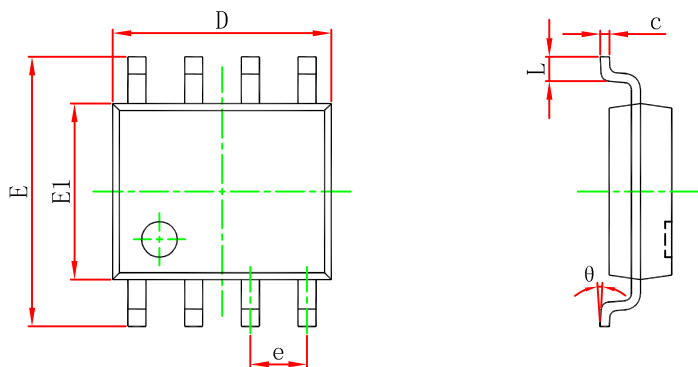

Symbol	Dimensions In Millimeters		Dimensions In Inches	
	Min	Max	Min	Max
A	1.370	1.670	0.054	0.066
A1	0.070	0.250	0.003	0.010
A2	1.350	1.550	0.053	0.061
b	0.300	0.510	0.013	0.020
c	0.170	0.250	0.007	0.010
D	4.700	5.100	0.185	0.201
e	1.270 (BSC)		0.050 (BSC)	
E	5.800	6.200	0.228	0.244
E1	3.800	4.000	0.150	0.157
L	0.400	1.270	0.016	0.050
theta	0°	8°	0°	8°

SOP8 Suggest Pad Layout

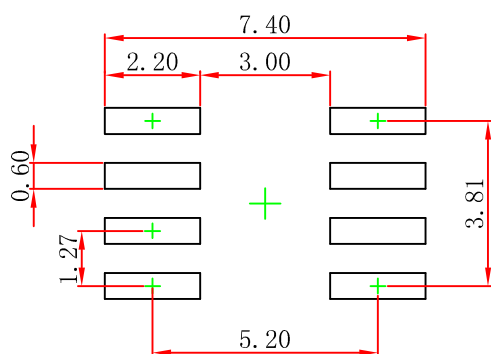

NOTE:

1. Controlling dimension: in millimeters.
2. General tolerance: $\pm 0.05\text{mm}$.
3. The pad layout is for reference purposes only.

Packaging Information

SOP8 Tape and Reel Information

Embossed Carrier Tape

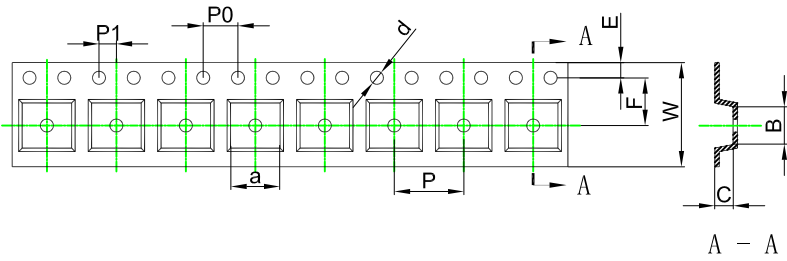

Packaging Description:

SOP8 parts are shipped in tape. The carrier tape is made from a dissipative (carbon filled) polycarbonate resin. The cover tape is a multilayer film (Heat Activated Adhesive in nature) primarily composed of polyester film, adhesive layer, sealant, and anti-static sprayed agent. These reeled parts in standard option are shipped with 2,500 units per 13" or 33cm diameter reel. The reels are clear in color and is made of polystyrene plastic (anti-static coated).
ALL DIM IN mm

Dimensions are in millimeter										
Pkg type	a	B	C	d	E	F	P0	P	P1	W
SOP8	6.40	5.40	2.10	Ø1.50	1.75	5.50	4.00	8.00	2.00	12.00

Tape Leader and Trailer

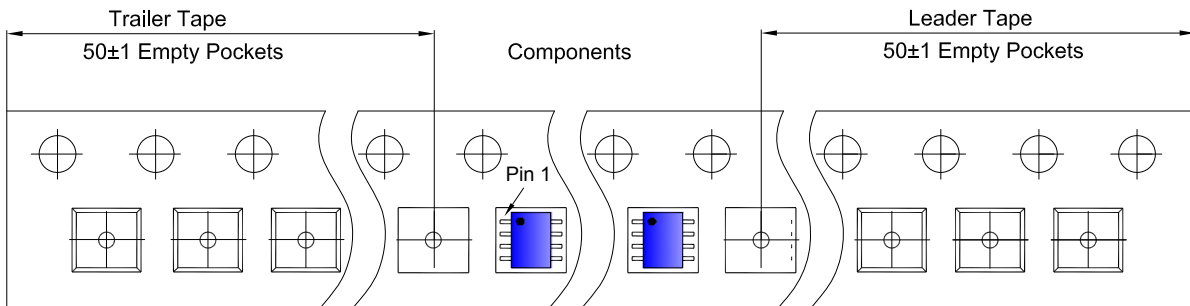

Reel

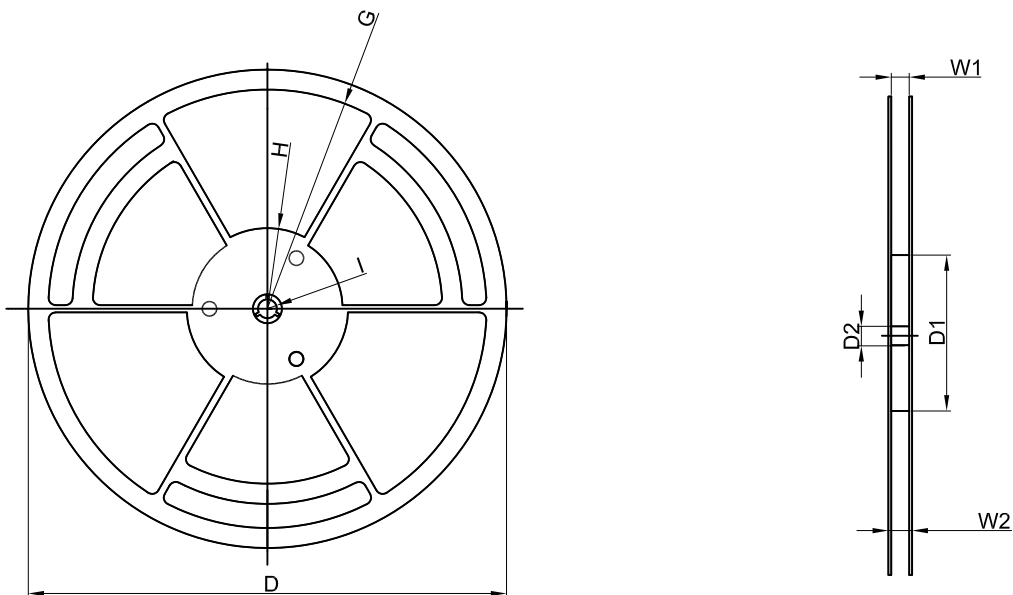

Dimensions are in millimeter								
Reel Option	D	D1	D2	G	H	I	W1	W2
13" Dia	Ø330.00	100.00	13.00	R151.00	R56.00	R6.50	12.40	17.60

REEL	Reel Size	Box	Box Size(mm)	Carton	Carton Size(mm)	G.W.(kg)
4,000 pcs	13 inch	8,000 pcs	360×360×65	64,000 pcs	565×380×390	

DISCLAIMER

IMPORTANT NOTICE, PLEASE READ CAREFULLY

The information in this data sheet is intended to describe the operation and characteristics of our products. JSCJ has the right to make any modification, enhancement, improvement, correction or other changes to any content in this data sheet, including but not limited to specification parameters, circuit design and application information, without prior notice.

Any person who purchases or uses JSCJ products for design shall: 1. Select products suitable for circuit application and design; 2. Design, verify and test the rationality of circuit design; 3. Procedures to ensure that the design complies with relevant laws and regulations and the requirements of such laws and regulations. JSCJ makes no warranty or representation as to the accuracy or completeness of the information contained in this data sheet and assumes no responsibility for the application or use of any of the products described in this data sheet.

Without the written consent of JSCJ, this product shall not be used in occasions requiring high quality or high reliability, including but not limited to the following occasions: medical equipment, military facilities and aerospace. JSCJ shall not be responsible for casualties or property losses caused by abnormal use or application of this product.

Official Website: www.jscj-elec.com